



US011928604B2

(12) **United States Patent**
Cheyer et al.

(10) **Patent No.:** **US 11,928,604 B2**

(45) **Date of Patent:** **Mar. 12, 2024**

(54) **METHOD AND APPARATUS FOR BUILDING AN INTELLIGENT AUTOMATED ASSISTANT**

(56) **References Cited**

(71) Applicant: **Apple Inc.**, Cupertino, CA (US)

U.S. PATENT DOCUMENTS

(72) Inventors: **Adam Cheyer**, Oakland, CA (US);
Didier Guzzoni, Montsur-Rolle (CH)

4,868,733 A * 9/1989 Fujisawa G06F 16/93
707/999.005
4,905,163 A * 2/1990 Garber G06F 16/2428
706/55

(73) Assignee: **Apple Inc.**

(Continued)

(*) Notice: Subject to any disclaimer, the term of this patent is extended or adjusted under 35 U.S.C. 154(b) by 643 days.

FOREIGN PATENT DOCUMENTS

AU 2015203483 A1 7/2015
AU 2015101171 A4 10/2015

(Continued)

(21) Appl. No.: **16/379,048**

(22) Filed: **Apr. 9, 2019**

OTHER PUBLICATIONS

(65) **Prior Publication Data**

Jonathan P Wanderer, Real-Time Alerts and Reminders Using Information Systems. (Year: 2011).*

US 2019/0236459 A1 Aug. 1, 2019

(Continued)

Related U.S. Application Data

(63) Continuation of application No. 15/299,264, filed on Oct. 20, 2016, now Pat. No. 10,318,871, which is a (Continued)

Primary Examiner — Lechi Truong

(74) *Attorney, Agent, or Firm* — DLA Piper LLP (US)

(51) **Int. Cl.**
G06F 3/00 (2006.01)
G06F 9/54 (2006.01)

(Continued)

(57) **ABSTRACT**

A method and apparatus are provided for building an intelligent automated assistant. Embodiments of the present invention rely on the concept of “active ontologies” (e.g., execution environments constructed in an ontology-like manner) to build and run applications for use by intelligent automated assistants. In one specific embodiment, a method for building an automated assistant includes interfacing a service-oriented architecture that includes a plurality of remote services to an active ontology, where the active ontology includes at least one active processing element that models a domain. At least one of the remote services is then registered for use in the domain.

(52) **U.S. Cl.**
CPC **G06N 5/022** (2013.01); **G06F 9/54** (2013.01); **G06F 9/542** (2013.01); **G06N 5/02** (2013.01);

(Continued)

(58) **Field of Classification Search**
CPC G06F 9/547; G06F 9/542; G06N 5/02; G06N 5/42

(Continued)

45 Claims, 6 Drawing Sheets

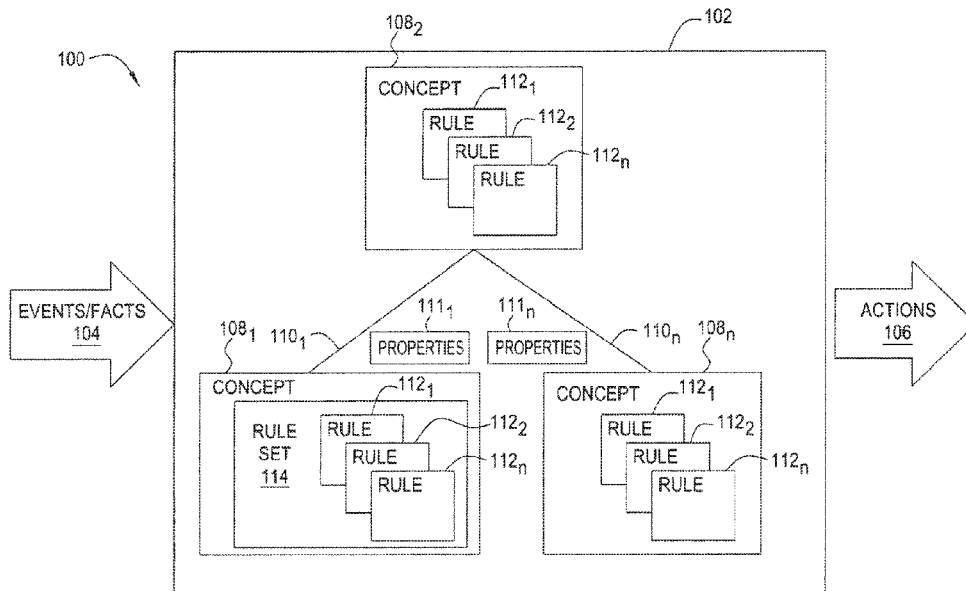

Related U.S. Application Data

- continuation of application No. 14/141,261, filed on Dec. 26, 2013, now Pat. No. 9,501,741, which is a continuation of application No. 11/518,292, filed on Sep. 8, 2006, now Pat. No. 8,677,377.
- (60) Provisional application No. 60/715,324, filed on Sep. 8, 2005.
- (51) **Int. Cl.**
G06N 5/02 (2023.01)
G06N 5/022 (2023.01)
G06N 7/01 (2023.01)
G09B 21/00 (2006.01)
G09B 23/28 (2006.01)
- (52) **U.S. Cl.**
 CPC *G06N 7/01* (2023.01); *G09B 21/00* (2013.01); *G09B 23/28* (2013.01)
- (58) **Field of Classification Search**
 USPC 719/311
 See application file for complete search history.

(56) **References Cited**

U.S. PATENT DOCUMENTS

5,157,779	A	10/1992	Washburn et al.
5,680,617	A	10/1997	Gough et al.
5,696,916	A *	12/1997	Yamazaki G06F 40/30 715/853
5,758,083	A	5/1998	Singh et al.
5,787,234	A *	7/1998	Molloy G06N 5/027 706/54
6,178,416	B1 *	1/2001	Thompson G06F 16/2428 707/999.005
6,321,179	B1	11/2001	Glance et al.
6,411,924	B1	6/2002	de Hita et al.
6,694,329	B2 *	2/2004	Murray G06F 16/93 707/999.005
6,760,412	B1 *	7/2004	Loucks H04M 3/42 379/207.03
7,027,974	B1 *	4/2006	Busch G06F 40/253 704/4
7,292,579	B2	11/2007	Morris
7,475,010	B2	1/2009	Chao
7,475,015	B2	1/2009	Epstein et al.
7,475,063	B2	1/2009	Datta et al.
7,477,238	B2	1/2009	Fux et al.
7,477,240	B2	1/2009	Yanagisawa
7,478,037	B2	1/2009	Strong
7,478,091	B2	1/2009	Mojsilovic et al.
7,478,129	B1	1/2009	Chemtob
7,479,948	B2	1/2009	Kim et al.
7,479,949	B2	1/2009	Jobs et al.
7,483,832	B2	1/2009	Tischer
7,483,894	B2	1/2009	Cao
7,487,089	B2	2/2009	Mozer
7,487,093	B2	2/2009	Mutsuno et al.
7,490,034	B2	2/2009	Finnigan et al.
7,490,039	B1	2/2009	Shaffer et al.
7,493,251	B2	2/2009	Gao et al.
7,493,560	B1	2/2009	Kipnes et al.
7,496,498	B2	2/2009	Chu et al.
7,496,512	B2	2/2009	Zhao et al.
7,499,923	B2	3/2009	Kawatani
7,502,738	B2	3/2009	Kennewick et al.
7,505,795	B1	3/2009	Lim et al.
7,508,324	B2	3/2009	Suraqui
7,508,373	B2	3/2009	Lin et al.
7,516,123	B2	4/2009	Betz et al.
7,519,327	B2	4/2009	White
7,519,398	B2	4/2009	Hirose
7,522,927	B2	4/2009	Fitch et al.
7,523,036	B2	4/2009	Akabane et al.

7,523,108	B2	4/2009	Cao
7,526,466	B2	4/2009	Au
7,526,738	B2	4/2009	Ording et al.
7,528,713	B2	5/2009	Singh et al.
7,529,671	B2	5/2009	Rockenbeck et al.
7,529,676	B2	5/2009	Koyama
7,529,677	B1	5/2009	Wittenber
7,535,997	B1	5/2009	McQuaide, Jr. et al.
7,536,029	B2	5/2009	Choi et al.
7,536,565	B2	5/2009	Girish et al.
7,538,685	B1	5/2009	Cooper et al.
7,539,619	B1	5/2009	Seligman et al.
7,539,656	B2	5/2009	Fratkina et al.
7,541,940	B2	6/2009	Upton
7,542,967	B2	6/2009	Hurst-Hiller et al.
7,542,971	B2	6/2009	Thione et al.
7,543,232	B2	6/2009	Easton, Jr. et al.
7,546,382	B2	6/2009	Healey et al.
7,546,529	B2	6/2009	Reynar et al.
7,548,895	B2	6/2009	Pulsipher
7,552,045	B2	6/2009	Barliga et al.
7,552,055	B2	6/2009	Lecoeuche
7,555,431	B2	6/2009	Bennett
7,555,496	B1	6/2009	Lantrip et al.
7,558,381	B1	7/2009	Ali et al.
7,558,730	B2	7/2009	Davis et al.
7,559,026	B2	7/2009	Girish et al.
7,561,069	B2	7/2009	Horstemeyer
7,562,007	B2	7/2009	Hwang
7,562,032	B2	7/2009	Abbosh et al.
7,565,104	B1	7/2009	Brown et al.
7,565,380	B1	7/2009	Venkatachary
7,568,151	B2	7/2009	Bargeron et al.
7,571,092	B1	8/2009	Nieh
7,571,106	B2	8/2009	Cao et al.
7,577,522	B2	8/2009	Rosenberg
7,580,551	B1	8/2009	Srihari et al.
7,580,576	B2	8/2009	Wang et al.
7,580,839	B2	8/2009	Tamura et al.
7,584,092	B2	9/2009	Brockett et al.
7,584,093	B2	9/2009	Potter et al.
7,584,278	B2	9/2009	Rajarajan et al.
7,584,429	B2	9/2009	Fabritius
7,593,868	B2	9/2009	Margiloff et al.
7,596,269	B2	9/2009	King et al.
7,596,499	B2	9/2009	Anguera et al.
7,596,606	B2	9/2009	Codignotto
7,596,765	B2	9/2009	Almas
7,599,918	B2	10/2009	Shen et al.
7,603,349	B1	10/2009	Kraft et al.
7,603,381	B2	10/2009	Burke et al.
7,603,684	B1	10/2009	Ellis
7,606,444	B1	10/2009	Erol et al.
7,606,712	B1	10/2009	Smith et al.
7,607,083	B2	10/2009	Gong et al.
7,609,179	B2	10/2009	Diaz-Gutierrez et al.
7,610,258	B2	10/2009	Yuknewicz et al.
7,613,264	B2	11/2009	Wells et al.
7,614,008	B2	11/2009	Ording
7,617,094	B2	11/2009	Aoki et al.
7,620,407	B1	11/2009	Donald et al.
7,620,549	B2	11/2009	Di Cristo et al.
7,620,894	B1	11/2009	Kahn
7,623,119	B2	11/2009	Autio et al.
7,624,007	B2	11/2009	Bennett
7,627,481	B1	12/2009	Kuo et al.
7,630,900	B1	12/2009	Strom
7,630,901	B2	12/2009	Omi
7,633,076	B2	12/2009	Huppi et al.
7,634,409	B2	12/2009	Kennewick et al.
7,634,413	B1	12/2009	Kuo et al.
7,634,718	B2	12/2009	Nakajima
7,634,732	B1	12/2009	Blagsvedt et al.
7,636,657	B2	12/2009	Ju et al.
7,640,158	B2	12/2009	Detlef et al.
7,640,160	B2	12/2009	Di Cristo et al.
7,643,990	B1	1/2010	Bellegarda
7,647,225	B2	1/2010	Bennett et al.
7,649,454	B2	1/2010	Singh et al.

(56)

References Cited

U.S. PATENT DOCUMENTS

7,649,877	B2	1/2010	Vieri et al.	7,743,188	B2	6/2010	Haitani et al.
7,653,883	B2	1/2010	Hotelling et al.	7,747,616	B2	6/2010	Yamada et al.
7,656,393	B2	2/2010	King et al.	7,752,152	B2	7/2010	Paek et al.
7,657,424	B2	2/2010	Bennett	7,756,707	B2	7/2010	Garner et al.
7,657,430	B2	2/2010	Ogawa	7,756,708	B2	7/2010	Cohen et al.
7,657,828	B2	2/2010	Lucas et al.	7,756,868	B2	7/2010	Lee
7,657,844	B2	2/2010	Gibson et al.	7,756,871	B2	7/2010	Yacoub et al.
7,657,849	B2	2/2010	Chaudhri et al.	7,757,173	B2	7/2010	Beaman
7,660,715	B1	2/2010	Thambiratnam	7,757,176	B2	7/2010	Vakil et al.
7,663,607	B2	2/2010	Hotelling et al.	7,757,182	B2	7/2010	Elliott et al.
7,664,558	B2	2/2010	Lindahl et al.	7,761,296	B1	7/2010	Bakis et al.
7,664,638	B2	2/2010	Cooper et al.	7,763,842	B2	7/2010	Hsu et al.
7,668,710	B2	2/2010	Doyle	7,774,202	B2	8/2010	Spengler et al.
7,669,134	B1	2/2010	Christie et al.	7,774,204	B2	8/2010	Mozer et al.
7,672,841	B2	3/2010	Bennett	7,774,388	B1	8/2010	Runchey
7,672,952	B2	3/2010	Isaacson et al.	7,777,717	B2	8/2010	Fux et al.
7,673,238	B2	3/2010	Girish et al.	7,778,432	B2	8/2010	Larsen
7,673,251	B1	3/2010	Wibisono	7,778,595	B2	8/2010	White et al.
7,673,340	B1	3/2010	Cohen et al.	7,778,632	B2	8/2010	Kurlander et al.
7,676,026	B1	3/2010	Baxter, Jr.	7,778,830	B2	8/2010	Davis et al.
7,676,365	B2	3/2010	Hwang et al.	7,779,353	B2	8/2010	Grigoriu et al.
7,676,463	B2	3/2010	Thompson et al.	7,779,356	B2	8/2010	Griesmer
7,679,534	B2	3/2010	Kay et al.	7,779,357	B2	8/2010	Naik
7,680,649	B2	3/2010	Park	7,783,283	B2	8/2010	Kuusinen et al.
7,681,126	B2	3/2010	Roose	7,783,486	B2	8/2010	Rosser et al.
7,683,886	B2	3/2010	Willy	7,788,590	B2	8/2010	Taboada et al.
7,683,893	B2	3/2010	Kim	7,788,663	B2	8/2010	Illowsky et al.
7,684,985	B2	3/2010	Dominach et al.	7,796,980	B1	9/2010	McKinney et al.
7,684,990	B2	3/2010	Caskey et al.	7,797,265	B2	9/2010	Brinker et al.
7,684,991	B2	3/2010	Stohr et al.	7,797,269	B2	9/2010	Rieman et al.
7,689,245	B2	3/2010	Cox et al.	7,797,331	B2	9/2010	Theimer et al.
7,689,408	B2	3/2010	Chen et al.	7,797,629	B2	9/2010	Fux et al.
7,689,409	B2	3/2010	Heinecke	7,801,721	B2	9/2010	Rosart et al.
7,689,412	B2	3/2010	Wu et al.	7,801,728	B2	9/2010	Ben-David et al.
7,689,421	B2	3/2010	Li et al.	7,801,729	B2	9/2010	Mozer
7,693,715	B2	4/2010	Hwang et al.	7,805,299	B2	9/2010	Coifman
7,693,717	B2	4/2010	Kahn et al.	7,809,550	B1	10/2010	Barrows
7,693,719	B2	4/2010	Chu et al.	7,809,565	B2	10/2010	Coifman
7,693,720	B2	4/2010	Kennewick et al.	7,809,569	B2	10/2010	Attwater et al.
7,698,131	B2	4/2010	Bennett	7,809,570	B2	10/2010	Kennewick et al.
7,702,500	B2	4/2010	Blaedow	7,809,610	B2	10/2010	Cao
7,702,508	B2	4/2010	Bennett	7,809,744	B2	10/2010	Nevidomski et al.
7,703,091	B1	4/2010	Martin et al.	7,818,165	B2	10/2010	Carligen et al.
7,706,510	B2	4/2010	Ng	7,818,176	B2	10/2010	Freeman et al.
7,707,026	B2	4/2010	Liu	7,818,215	B2	10/2010	King et al.
7,707,027	B2	4/2010	Balchandran et al.	7,818,291	B2	10/2010	Ferguson et al.
7,707,032	B2	4/2010	Wang et al.	7,818,672	B2	10/2010	Mccormack et al.
7,707,221	B1	4/2010	Dunning et al.	7,822,608	B2	10/2010	Cross, Jr. et al.
7,707,226	B1	4/2010	Tonse	7,823,123	B2	10/2010	Sabbouh
7,707,267	B2	4/2010	Lisitsa et al.	7,826,945	B2	11/2010	Zhang et al.
7,710,262	B2	5/2010	Ruha	7,827,047	B2	11/2010	Anderson et al.
7,711,129	B2	5/2010	Lindahl et al.	7,831,246	B1	11/2010	Smith et al.
7,711,550	B1	5/2010	Feinberg et al.	7,831,423	B2	11/2010	Schubert
7,711,565	B1	5/2010	Gazdzinski	7,831,426	B2	11/2010	Bennett
7,711,672	B2	5/2010	Au	7,831,432	B2	11/2010	Bodin et al.
7,712,053	B2	5/2010	Bradford et al.	7,835,504	B1	11/2010	Donald et al.
7,716,056	B2	5/2010	Weng et al.	7,836,437	B2	11/2010	Kacmarcik et al.
7,716,216	B1	5/2010	Harik et al.	7,840,348	B2	11/2010	Kim et al.
7,720,674	B2	5/2010	Kaiser et al.	7,840,400	B2	11/2010	Lavi et al.
7,720,683	B1	5/2010	Vermeulen et al.	7,840,447	B2	11/2010	Kleinrock et al.
7,721,226	B2	5/2010	Barabe et al.	7,840,581	B2	11/2010	Ross et al.
7,721,301	B2	5/2010	Wong et al.	7,840,912	B2	11/2010	Elias et al.
7,724,242	B2	5/2010	Hillis et al.	7,844,394	B2	11/2010	Kim
7,724,696	B1	5/2010	Parekh	7,848,924	B2	12/2010	Nurminen et al.
7,725,307	B2	5/2010	Bennett	7,848,926	B2	12/2010	Goto et al.
7,725,318	B2	5/2010	Gavalda et al.	7,853,444	B2	12/2010	Wang et al.
7,725,320	B2	5/2010	Bennett	7,853,445	B2	12/2010	Bachenko et al.
7,725,321	B2	5/2010	Bennett	7,853,574	B2	12/2010	Kraenzel et al.
7,725,838	B2	5/2010	Williams	7,853,577	B2	12/2010	Sundaresan et al.
7,729,904	B2	6/2010	Bennett	7,853,664	B1	12/2010	Wang et al.
7,729,916	B2	6/2010	Coffman et al.	7,853,900	B2	12/2010	Nguyen et al.
7,734,461	B2	6/2010	Kwak et al.	7,865,817	B2	1/2011	Ryan et al.
7,735,012	B2	6/2010	Naik	7,869,998	B1	1/2011	Di Fabbriozio et al.
7,739,588	B2	6/2010	Reynar et al.	7,869,999	B2	1/2011	Amato et al.
7,742,953	B2	6/2010	King et al.	7,870,118	B2	1/2011	Jiang et al.
				7,870,133	B2	1/2011	Krishnamoorthy et al.
				7,873,149	B2	1/2011	Schultz et al.
				7,873,519	B2	1/2011	Bennett
				7,873,654	B2	1/2011	Bernard

(56)

References Cited

U.S. PATENT DOCUMENTS

7,877,705 B2	1/2011	Chambers et al.	8,015,006 B2	9/2011	Kennewick et al.
7,880,730 B2	2/2011	Robinson et al.	8,015,011 B2	9/2011	Nagano et al.
7,881,283 B2	2/2011	Cormier et al.	8,015,144 B2	9/2011	Zheng et al.
7,881,936 B2	2/2011	Longe et al.	8,018,431 B1	9/2011	Zehr et al.
7,885,390 B2	2/2011	Chaudhuri et al.	8,019,271 B1	9/2011	Izdepski
7,885,844 B1	2/2011	Cohen et al.	8,019,604 B2	9/2011	Ma
7,886,233 B2	2/2011	Rainisto et al.	8,020,104 B2	9/2011	Robarts et al.
7,889,101 B2	2/2011	Yokota	8,024,195 B2	9/2011	Mozer et al.
7,889,184 B2	2/2011	Blumenberg et al.	8,024,415 B2	9/2011	Horvitz et al.
7,889,185 B2	2/2011	Blumenberg et al.	8,027,836 B2	9/2011	Baker et al.
7,890,330 B2	2/2011	Ozkaragoz et al.	8,031,943 B2	10/2011	Chen et al.
7,890,652 B2	2/2011	Bull et al.	8,032,383 B1	10/2011	Bhardwaj et al.
7,895,039 B2	2/2011	Braho et al.	8,036,901 B2	10/2011	Mozer
7,895,531 B2	2/2011	Radtke et al.	8,037,034 B2	10/2011	Plachta et al.
7,899,666 B2	3/2011	Varone	8,041,557 B2	10/2011	Liu
7,904,297 B2	3/2011	Mirkovic et al.	8,041,570 B2	10/2011	Mirkovic et al.
7,908,287 B1	3/2011	Katragadda	8,041,611 B2	10/2011	Kleinrock et al.
7,912,289 B2	3/2011	Kansal et al.	8,042,053 B2	10/2011	Darwish et al.
7,912,699 B1	3/2011	Saraclar et al.	8,046,231 B2	10/2011	Hirota et al.
7,912,702 B2	3/2011	Bennett	8,046,363 B2	10/2011	Cha et al.
7,912,720 B1	3/2011	Hakkani-Tur et al.	8,046,374 B1	10/2011	Bromwich et al.
7,912,828 B2	3/2011	Bonnet et al.	8,050,500 B1	11/2011	Batty et al.
7,913,185 B1	3/2011	Benson et al.	8,054,180 B1	11/2011	Scotfield et al.
7,916,979 B2	3/2011	Simmons	8,055,296 B1	11/2011	Persson et al.
7,917,367 B2	3/2011	Di Cristo et al.	8,055,502 B2	11/2011	Clark et al.
7,917,497 B2	3/2011	Harrison et al.	8,055,708 B2	11/2011	Chitsaz et al.
7,920,678 B2	4/2011	Cooper et al.	8,056,070 B2	11/2011	Goller et al.
7,920,682 B2	4/2011	Byrne et al.	8,060,824 B2	11/2011	Brownrigg, Jr. et al.
7,920,857 B2	4/2011	Lau et al.	8,064,753 B2	11/2011	Freeman
7,925,525 B2	4/2011	Chin	8,065,143 B2	11/2011	Yanagihara
7,925,610 B2	4/2011	Elbaz et al.	8,065,155 B1	11/2011	Gazdzinski
7,929,805 B2	4/2011	Wang et al.	8,065,156 B2	11/2011	Gazdzinski
7,930,168 B2	4/2011	Weng et al.	8,068,604 B2	11/2011	Leeds et al.
7,930,183 B2	4/2011	Odell et al.	8,069,046 B2	11/2011	Kennewick et al.
7,930,197 B2	4/2011	Ozzie et al.	8,069,422 B2	11/2011	Sheshagiri et al.
7,936,339 B2	5/2011	Marggraff et al.	8,073,681 B2	12/2011	Baldwin et al.
7,936,861 B2	5/2011	Martin et al.	8,073,695 B1	12/2011	Hendricks et al.
7,936,863 B2	5/2011	John et al.	8,077,153 B2	12/2011	Benko et al.
7,937,075 B2	5/2011	Zellner	8,078,473 B1	12/2011	Gazdzinski
7,941,009 B2	5/2011	Li et al.	8,082,153 B2	12/2011	Coffman et al.
7,945,294 B2	5/2011	Zhang et al.	8,082,498 B2	12/2011	Salamon et al.
7,945,470 B1	5/2011	Cohen et al.	8,090,571 B2	1/2012	Elshishiny et al.
7,949,529 B2	5/2011	Weider et al.	8,095,364 B2	1/2012	Longe et al.
7,949,534 B2	5/2011	Davis et al.	8,099,289 B2	1/2012	Mozer et al.
7,949,752 B2	5/2011	Lange et al.	8,099,395 B2	1/2012	Pabla et al.
7,953,679 B2	5/2011	Chidlovskii et al.	8,099,418 B2	1/2012	Inoue et al.
7,957,975 B2	6/2011	Burns et al.	8,103,510 B2	1/2012	Sato
7,958,136 B1	6/2011	Curtis et al.	8,107,401 B2	1/2012	John et al.
7,962,179 B2	6/2011	Huang	8,112,275 B2	2/2012	Kennewick et al.
7,974,835 B2	7/2011	Balchandran et al.	8,112,280 B2	2/2012	Lu
7,974,844 B2	7/2011	Sumita	8,117,037 B2	2/2012	Gazdzinski
7,974,972 B2	7/2011	Cao	8,117,542 B2	2/2012	Radtke et al.
7,975,216 B2	7/2011	Woolf et al.	8,121,413 B2	2/2012	Hwang et al.
7,983,478 B2	7/2011	Liu et al.	8,121,837 B2	2/2012	Agapi et al.
7,983,915 B2	7/2011	Knight et al.	8,122,094 B1	2/2012	Kotab
7,983,917 B2	7/2011	Kennewick et al.	8,122,353 B2	2/2012	Bouta
7,983,919 B2	7/2011	Conkie	8,130,929 B2	3/2012	Wilkes et al.
7,983,997 B2	7/2011	Allen et al.	8,131,557 B2	3/2012	Davis et al.
7,984,062 B2	7/2011	Dunning et al.	8,135,115 B1	3/2012	Hogg, Jr. et al.
7,986,431 B2	7/2011	Emori et al.	8,138,912 B2	3/2012	Singh et al.
7,987,151 B2	7/2011	Schott et al.	8,140,330 B2	3/2012	Cevik et al.
7,987,244 B1	7/2011	Lewis et al.	8,140,335 B2	3/2012	Kennewick et al.
7,991,614 B2	8/2011	Washio et al.	8,140,567 B2	3/2012	Padovitz et al.
7,992,085 B2	8/2011	Wang-Aryattanwanich et al.	8,145,489 B2	3/2012	Freeman et al.
7,996,228 B2	8/2011	Miller et al.	8,150,694 B2	4/2012	Kennewick et al.
7,996,589 B2	8/2011	Schultz et al.	8,150,700 B2	4/2012	Shin et al.
7,996,769 B2	8/2011	Fux et al.	8,155,956 B2	4/2012	Cho et al.
7,996,792 B2	8/2011	Anzures et al.	8,156,005 B2	4/2012	Vieri
7,999,669 B2	8/2011	Singh et al.	8,160,877 B1	4/2012	Nucci et al.
8,000,453 B2	8/2011	Cooper et al.	8,160,883 B2	4/2012	Lecoeuche
8,005,664 B2	8/2011	Hanumanthappa	8,165,321 B2	4/2012	Paquier et al.
8,005,679 B2	8/2011	Jordan et al.	8,165,886 B1	4/2012	Gagnon et al.
8,006,180 B2	8/2011	Tunning et al.	8,166,019 B1	4/2012	Lee et al.
8,010,614 B1	8/2011	Musat et al.	8,166,032 B2	4/2012	Sommer et al.
8,014,308 B2	9/2011	Gates et al.	8,170,790 B2	5/2012	Lee et al.
			8,170,966 B1	5/2012	Musat et al.
			8,175,872 B2	5/2012	Kristjansson et al.
			8,175,876 B2	5/2012	Bou-Ghazale et al.
			8,179,370 B1	5/2012	Yamasani et al.

(56)

References Cited

U.S. PATENT DOCUMENTS

8,188,856	B2	5/2012	Singh et al.	8,371,503	B2	2/2013	Gazdzinski
8,190,359	B2	5/2012	Bourne	8,374,871	B2	2/2013	Ehsani et al.
8,190,596	B2	5/2012	Nambiar et al.	8,375,320	B2	2/2013	Kotler et al.
8,194,827	B2	6/2012	Jaiswal et al.	8,380,504	B1	2/2013	Peden et al.
8,195,467	B2	6/2012	Mozer et al.	8,380,507	B2	2/2013	Herman et al.
8,195,468	B2	6/2012	Kennewick et al.	8,381,107	B2	2/2013	Rottler et al.
8,200,489	B1	6/2012	Baggenstoss	8,381,135	B2	2/2013	Hotelling et al.
8,200,495	B2	6/2012	Braho et al.	8,386,485	B2	2/2013	Kerschberg et al.
8,201,109	B2	6/2012	Van Os et al.	8,386,926	B1	2/2013	Matsuoka
8,204,238	B2	6/2012	Mozer	8,391,844	B2	3/2013	Lamiroux et al.
8,205,788	B1	6/2012	Gazdzinski et al.	8,396,714	B2	3/2013	Rogers et al.
8,209,183	B1	6/2012	Patel et al.	8,401,163	B1	3/2013	Kirchhoff et al.
8,213,911	B2	7/2012	Williams et al.	8,406,745	B1	3/2013	Upadhyay et al.
8,219,115	B1	7/2012	Nelissen	8,423,288	B2	4/2013	Stahl et al.
8,219,406	B2	7/2012	Yu et al.	8,428,758	B2	4/2013	Naik et al.
8,219,407	B1	7/2012	Roy et al.	8,433,572	B2	4/2013	Caskey et al.
8,219,608	B2	7/2012	alSafadi et al.	8,433,778	B1	4/2013	Shreesha et al.
8,224,649	B2	7/2012	Chaudhari et al.	8,442,821	B1	5/2013	Vanhoucke
8,224,757	B2	7/2012	Bohle	8,447,612	B2	5/2013	Gazdzinski
8,228,299	B1	7/2012	Maloney et al.	8,452,597	B2	5/2013	Bringert et al.
8,233,919	B2	7/2012	Haag et al.	8,452,602	B1	5/2013	Bringert et al.
8,234,111	B2	7/2012	Lloyd et al.	8,457,959	B2	6/2013	Kaiser
8,239,206	B1	8/2012	LeBeau et al.	8,458,115	B2	6/2013	Cai et al.
8,239,207	B2	8/2012	Seligman et al.	8,458,278	B2	6/2013	Christie et al.
8,244,712	B2	8/2012	Serlet et al.	8,464,150	B2	6/2013	Davidson et al.
8,250,071	B1	8/2012	Killalea et al.	8,473,289	B2	6/2013	Jitkoff et al.
8,254,829	B1	8/2012	Kindred et al.	8,479,122	B2	7/2013	Hotelling et al.
8,255,216	B2	8/2012	White	8,484,027	B1	7/2013	Murphy
8,255,217	B2	8/2012	Stent et al.	8,489,599	B2	7/2013	Bellotti
8,260,247	B2	9/2012	Lazaridis et al.	8,498,857	B2	7/2013	Kopparapu et al.
8,260,617	B2	9/2012	Dhanakshirur et al.	8,514,197	B2	8/2013	Shahraray et al.
8,270,933	B2	9/2012	Riemer et al.	8,515,736	B1	8/2013	Duta
8,271,287	B1	9/2012	Kermani	8,515,750	B1	8/2013	Lei et al.
8,275,621	B2	9/2012	Alewine et al.	8,521,513	B2	8/2013	Millett et al.
8,279,171	B2	10/2012	Hirai et al.	8,521,531	B1	8/2013	Kim
8,280,438	B2	10/2012	Barbera	8,527,276	B1	9/2013	Senior et al.
8,285,546	B2	10/2012	Reich	8,537,033	B2	9/2013	Gueziec
8,285,551	B2	10/2012	Gazdzinski	8,539,342	B1	9/2013	Lewis
8,285,553	B2	10/2012	Gazdzinski	8,543,375	B2	9/2013	Hong
8,285,737	B1	10/2012	Lynn et al.	8,543,397	B1	9/2013	Nguyen
8,290,777	B1	10/2012	Nguyen et al.	8,543,398	B1	9/2013	Strope et al.
8,290,778	B2	10/2012	Gazdzinski	8,560,229	B1	10/2013	Park et al.
8,290,781	B2	10/2012	Gazdzinski	8,571,851	B1	10/2013	Tickner et al.
8,296,124	B1	10/2012	Holsztynska et al.	8,583,416	B2	11/2013	Huang et al.
8,296,145	B2	10/2012	Clark et al.	8,583,511	B2	11/2013	Hendrickson
8,296,146	B2	10/2012	Gazdzinski	8,589,156	B2	11/2013	Burke et al.
8,296,153	B2	10/2012	Gazdzinski	8,589,869	B2	11/2013	Wolfram
8,296,380	B1	10/2012	Kelly et al.	8,589,911	B1	11/2013	Sharkey et al.
8,296,383	B2	10/2012	Lindahl	8,595,004	B2	11/2013	Koshinaka
8,300,776	B2	10/2012	Davies et al.	8,600,743	B2	12/2013	Lindahl et al.
8,300,801	B2	10/2012	Sweeney et al.	8,600,746	B1	12/2013	Lei et al.
8,301,456	B2	10/2012	Gazdzinski	8,600,930	B2	12/2013	Sata et al.
8,311,189	B2	11/2012	Champlin et al.	8,606,090	B2	12/2013	Eyer
8,311,834	B1	11/2012	Gazdzinski	8,606,568	B1	12/2013	Tickner et al.
8,311,835	B2	11/2012	Lecoeuche	8,606,576	B1	12/2013	Barr et al.
8,311,838	B2	11/2012	Lindahl et al.	8,606,577	B1	12/2013	Stewart et al.
8,312,017	B2	11/2012	Martin et al.	8,620,659	B2	12/2013	Di Cristo et al.
8,321,786	B2	11/2012	Lunati et al.	8,620,662	B2	12/2013	Bellegarda
8,326,627	B2	12/2012	Kennewick et al.	8,626,681	B1	1/2014	Jurca et al.
8,332,205	B2	12/2012	Krishnan et al.	8,638,363	B2	1/2014	King et al.
8,332,218	B2	12/2012	Cross et al.	8,639,516	B2	1/2014	Lindahl et al.
8,332,224	B2	12/2012	Di Cristo et al.	8,645,137	B2	2/2014	Bellegarda et al.
8,332,748	B1	12/2012	Karam	8,645,138	B1	2/2014	Weinstein et al.
8,335,689	B2	12/2012	Wittenstein et al.	8,654,936	B1	2/2014	Tofighbakhsh et al.
8,340,975	B1	12/2012	Rosenberger	8,655,646	B2	2/2014	Lee et al.
8,345,665	B2	1/2013	Vieri et al.	8,655,901	B1	2/2014	Li et al.
8,346,563	B1	1/2013	Hjelm et al.	8,660,843	B2	2/2014	Falcon et al.
8,346,757	B1	1/2013	Lamping et al.	8,660,849	B2	2/2014	Gruber et al.
8,352,183	B2	1/2013	Thota et al.	8,660,970	B1	2/2014	Fiedorowicz
8,352,268	B2	1/2013	Naik et al.	8,661,112	B2	2/2014	Creamer et al.
8,352,272	B2	1/2013	Rogers et al.	8,661,340	B2	2/2014	Goldsmith et al.
8,355,919	B2	1/2013	Silverman et al.	8,670,979	B2	3/2014	Gruber et al.
8,359,234	B2	1/2013	Vieri	8,675,084	B2	3/2014	Bolton et al.
8,370,145	B2	2/2013	Endo et al.	8,676,904	B2	3/2014	Lindahl et al.
8,370,158	B2	2/2013	Gazdzinski	8,677,377	B2	3/2014	Cheyser et al.
				8,681,950	B2	3/2014	Vlack et al.
				8,682,667	B2	3/2014	Haughay et al.
				8,687,777	B1	4/2014	Lavian et al.
				8,688,446	B2	4/2014	Yanagihara et al.

(56)

References Cited

U.S. PATENT DOCUMENTS

8,688,453	B1	4/2014	Joshi et al.	9,058,811	B2	6/2015	Wang et al.
8,695,074	B2	4/2014	Saraf et al.	9,063,979	B2	6/2015	Chiu et al.
8,696,364	B2	4/2014	Cohen	9,064,495	B1	6/2015	Torok et al.
8,706,472	B2	4/2014	Ramerth et al.	9,070,366	B1	6/2015	Mathias et al.
8,706,474	B2	4/2014	Blume et al.	9,071,701	B2	6/2015	Donaldson et al.
8,706,503	B2	4/2014	Cheyser et al.	9,075,435	B1	7/2015	Nobel et al.
8,713,119	B2	4/2014	Lindahl et al.	9,076,448	B2	7/2015	Bennett et al.
8,713,418	B2	4/2014	King et al.	9,076,450	B1	7/2015	Sadek et al.
8,719,006	B2	5/2014	Bellegarda et al.	9,081,411	B2	7/2015	Kalns et al.
8,719,014	B2	5/2014	Wagner et al.	9,081,482	B1	7/2015	Zhai et al.
8,719,039	B1	5/2014	Sharifi	9,082,402	B2	7/2015	Yadgar et al.
8,731,610	B2	5/2014	Appaji	9,083,581	B1	7/2015	Addepalli et al.
8,731,912	B1	5/2014	Tickner et al.	9,098,467	B1	8/2015	Blanksteen et al.
8,731,942	B2	5/2014	Cheyser et al.	9,101,279	B2	8/2015	Ritchey et al.
8,739,208	B2	5/2014	Rodriguez et al.	9,112,984	B2	8/2015	Sejnoha et al.
8,744,852	B1	6/2014	Seymour et al.	9,117,447	B2	8/2015	Gruber et al.
8,760,537	B2	6/2014	Johnson et al.	9,123,338	B1	9/2015	Sanders et al.
8,762,145	B2	6/2014	Ouchi et al.	9,159,319	B1	10/2015	Hoffmeister
8,762,156	B2	6/2014	Chen et al.	9,164,983	B2	10/2015	Liu et al.
8,762,469	B2	6/2014	Lindahl et al.	9,171,541	B2	10/2015	Kennewick et al.
8,768,693	B2	7/2014	Lempel et al.	9,171,546	B1	10/2015	Pike
8,768,702	B2	7/2014	Boettcher et al.	9,183,845	B1	11/2015	Gopalakrishnan et al.
8,775,154	B2	7/2014	Clinchant et al.	9,190,062	B2	11/2015	Haughay
8,775,931	B2	7/2014	Fux et al.	9,208,153	B1	12/2015	Zaveri et al.
8,781,456	B2	7/2014	Prociw	9,218,809	B2	12/2015	Bellegarda
8,781,841	B1	7/2014	Wang	9,218,819	B1	12/2015	Stekkelpak et al.
8,798,255	B2	8/2014	Lubowich et al.	9,223,537	B2	12/2015	Brown et al.
8,798,995	B1	8/2014	Edara et al.	9,241,073	B1	1/2016	Van Rensburg et al.
8,799,000	B2	8/2014	Guzzoni et al.	9,255,812	B2	2/2016	Maeoka et al.
8,805,690	B1	8/2014	LeBeau et al.	9,258,604	B1	2/2016	Bilobrov et al.
8,812,302	B2	8/2014	Xiao et al.	9,262,612	B2	2/2016	Cheyser
8,823,507	B1	9/2014	Touloumtzis	9,280,535	B2	3/2016	Varma et al.
8,831,947	B2	9/2014	Wasserblat et al.	9,286,910	B1	3/2016	Li et al.
8,838,457	B2	9/2014	Cerra et al.	9,292,487	B1	3/2016	Weber
8,855,915	B2	10/2014	Furuhata et al.	9,292,489	B1	3/2016	Sak et al.
8,861,925	B1	10/2014	Ohme	9,299,344	B2	3/2016	Braho et al.
8,862,252	B2	10/2014	Rottler et al.	9,300,718	B2	3/2016	Khanna
8,868,409	B1	10/2014	Mengibar et al.	9,305,543	B2	4/2016	Fleizach et al.
8,880,405	B2	11/2014	Cerra et al.	9,305,548	B2	4/2016	Kennewick et al.
8,886,534	B2	11/2014	Nakano et al.	9,311,912	B1	4/2016	Swietlinski et al.
8,886,540	B2	11/2014	Cerra et al.	9,313,317	B1	4/2016	LeBeau et al.
8,886,541	B2	11/2014	Friedlander	9,318,108	B2	4/2016	Gruber et al.
8,892,446	B2	11/2014	Cheyser et al.	9,325,809	B1	4/2016	Barros et al.
8,893,023	B2	11/2014	Perry et al.	9,330,659	B2	5/2016	Ju et al.
8,898,568	B2	11/2014	Bull et al.	9,330,720	B2	5/2016	Lee
8,903,716	B2	12/2014	Chen et al.	9,338,493	B2	5/2016	Van Os et al.
8,909,693	B2	12/2014	Frissora et al.	9,349,368	B1	5/2016	LeBeau et al.
8,930,176	B2	1/2015	Li et al.	9,361,084	B1	6/2016	Costa
8,930,191	B2	1/2015	Gruber et al.	9,367,541	B1	6/2016	Servan et al.
8,938,394	B1	1/2015	Faaborg et al.	9,377,871	B2	6/2016	Waddell et al.
8,938,450	B2	1/2015	Spivack et al.	9,378,740	B1	6/2016	Rosen et al.
8,938,688	B2	1/2015	Bradford et al.	9,380,155	B1	6/2016	Reding et al.
8,942,986	B2	1/2015	Cheyser et al.	9,383,827	B1	7/2016	Faaborg et al.
8,943,423	B2	1/2015	Merrill et al.	9,390,726	B1	7/2016	Smus et al.
8,972,240	B2	3/2015	Brockett et al.	9,396,722	B2	7/2016	Chung et al.
8,972,432	B2	3/2015	Shaw et al.	9,401,147	B2	7/2016	Jitkoff et al.
8,972,878	B2	3/2015	Mohler et al.	9,406,224	B1	8/2016	Sanders et al.
8,983,383	B1	3/2015	Haskin	9,412,392	B2	8/2016	Lindahl
8,989,713	B2	3/2015	Doulton	9,418,650	B2	8/2016	Bharadwaj et al.
8,990,235	B2	3/2015	King et al.	9,423,266	B2	8/2016	Clark et al.
8,994,660	B2	3/2015	Neels et al.	9,424,840	B1	8/2016	Hart et al.
8,996,350	B1	3/2015	Dub et al.	9,436,918	B2	9/2016	Pantel et al.
8,996,376	B2	3/2015	Fleizach et al.	9,437,186	B1	9/2016	Liu et al.
8,996,381	B2	3/2015	Mozser et al.	9,437,189	B2	9/2016	Epstein et al.
8,996,639	B1	3/2015	Faaborg et al.	9,454,957	B1	9/2016	Mathias et al.
9,009,046	B1	4/2015	Stewart	9,465,833	B2	10/2016	Aravamudan et al.
9,020,804	B2	4/2015	Barbaiani et al.	9,471,566	B1	10/2016	Zhang et al.
9,026,425	B2	5/2015	Nikoulina et al.	9,484,021	B1	11/2016	Mairesse et al.
9,031,834	B2	5/2015	Coorman et al.	9,495,129	B2	11/2016	Fleizach et al.
9,037,967	B1	5/2015	Al-Jefri et al.	9,501,741	B2	11/2016	Cheyser et al.
9,043,208	B2	5/2015	Koch et al.	9,502,025	B2	11/2016	Kennewick et al.
9,043,211	B2	5/2015	Haiut et al.	9,508,028	B2	11/2016	Bannister et al.
9,049,255	B2	6/2015	MacFarlane et al.	9,510,044	B1	11/2016	Pereira et al.
9,049,295	B1	6/2015	Cooper et al.	9,514,470	B2	12/2016	Topatan et al.
9,053,706	B2	6/2015	Jitkoff et al.	9,519,453	B2	12/2016	Perkuhn et al.
				9,524,355	B2	12/2016	Forbes et al.
				9,535,906	B2	1/2017	Lee et al.
				9,536,527	B1	1/2017	Carlson
				9,547,647	B2	1/2017	Badaskar

(56)	References Cited	2005/0197992 A1 *	9/2005	Kipersztok	G06F 40/30 706/50
	U.S. PATENT DOCUMENTS	2006/0047649 A1 *	3/2006	Liang	G06F 16/338
		2006/0136194 A1 *	6/2006	Armstrong	G06F 16/36 704/4
	9,548,050 B2	1/2017	Gruber et al.		
	9,569,549 B1	2/2017	Jenkins et al.		
	9,575,964 B2	2/2017	Yadgar et al.		
	9,578,173 B2	2/2017	Sanghavi et al.		
	9,607,612 B2	3/2017	Deleeuw		
	9,620,113 B2	4/2017	Kennewick et al.		
	9,620,126 B2	4/2017	Chiba		
	9,626,955 B2	4/2017	Fleizach et al.		
	9,633,004 B2	4/2017	Giuli et al.		
	9,633,660 B2	4/2017	Haughay		
	9,652,453 B2	5/2017	Mathur et al.		
	9,658,746 B2	5/2017	Cohn et al.		
	9,659,298 B2	5/2017	Lynch et al.		
	9,665,567 B2	5/2017	Liu et al.		
	9,668,121 B2	5/2017	Naik et al.		
	9,672,725 B2	6/2017	Dotan-Cohen et al.		
	9,691,378 B1	6/2017	Meyers et al.		
	9,697,827 B1	7/2017	Lilly et al.		
	9,698,999 B2	7/2017	Mutagi		
	9,720,907 B2	8/2017	Bangalore et al.		
	9,721,566 B2	8/2017	Newendorp et al.		
	9,734,817 B1	8/2017	Putrycz		
	9,734,839 B1	8/2017	Adams		
	9,741,343 B1	8/2017	Miles et al.		
	9,747,083 B1	8/2017	Roman et al.		
	9,755,605 B1	9/2017	Li et al.		
	9,813,882 B1	11/2017	Masterman		
	9,818,400 B2	11/2017	Paulik et al.		
	9,842,584 B1	12/2017	Hart et al.		
	9,858,927 B2	1/2018	Williams et al.		
	9,934,785 B1	4/2018	Hulaud		
	9,948,728 B2	4/2018	Linn et al.		
	9,966,068 B2	5/2018	Cash et al.		
	9,967,381 B1	5/2018	Kashimba et al.		
	9,990,176 B1	6/2018	Gray		
	10,037,758 B2	7/2018	Jing et al.		
	10,049,663 B2	8/2018	Orr et al.		
	10,049,668 B2	8/2018	Huang et al.		
	10,055,681 B2	8/2018	Brown et al.		
	10,074,360 B2	9/2018	Kim		
	10,096,319 B1	10/2018	Jin et al.		
	10,102,359 B2	10/2018	Cheyer		
	10,127,901 B2	11/2018	Zhao et al.		
	10,169,329 B2	1/2019	Futrell et al.		
	10,170,123 B2	1/2019	Orr et al.		
	10,191,718 B2	1/2019	Rhee et al.		
	10,192,557 B2	1/2019	Lee et al.		
	10,200,824 B2	2/2019	Gross et al.		
	2002/0065797 A1	5/2002	Meidan et al.		
	2002/0078257 A1 *	6/2002	Nishimura	G06F 9/4812 719/318	
	2002/0178226 A1	11/2002	Anderson et al.		
	2003/0084350 A1	5/2003	Eibach et al.		
	2003/0174830 A1	9/2003	Boyer et al.		
	2003/0188192 A1	10/2003	Tang et al.		
	2004/0019603 A1 *	1/2004	Haigh	G06Q 10/109	
	2004/0030531 A1 *	2/2004	Miller	G08B 21/0423 702/182	
	2004/0030741 A1 *	2/2004	Wolton	G06F 16/954 709/202	
	2004/0054690 A1	3/2004	Hillerbrand et al.		
	2004/0068476 A1 *	4/2004	Provost	G06N 5/025 706/45	
	2004/0111754 A1	6/2004	Bushey et al.		
	2004/0162741 A1	8/2004	Flaxer et al.		
	2004/0193420 A1 *	9/2004	Kennewick	G06F 16/3329 704/257	
	2004/0230685 A1 *	11/2004	Seligmann	G01C 21/00 709/228	
	2005/0086255 A1	4/2005	Schran et al.		
	2005/0144162 A1 *	6/2005	Liang	G06F 16/338	
	2005/0154690 A1 *	7/2005	Nitta	G06F 16/30 707/E17.058	
		2007/0018953 A1 *	1/2007	Kipersztok	G06F 16/3323 707/E17.067
		2007/0100790 A1	5/2007	Cheyer et al.	
		2009/0003115 A1	1/2009	Lindahl et al.	
		2009/0005012 A1	1/2009	Van Heugten	
		2009/0005891 A1	1/2009	Batson et al.	
		2009/0006096 A1	1/2009	Li et al.	
		2009/0006097 A1	1/2009	Etezadi et al.	
		2009/0006099 A1	1/2009	Sharpe et al.	
		2009/0006100 A1	1/2009	Badger et al.	
		2009/0006343 A1	1/2009	Platt et al.	
		2009/0006345 A1	1/2009	Platt et al.	
		2009/0006488 A1	1/2009	Lindahl et al.	
		2009/0006671 A1	1/2009	Batson et al.	
		2009/0007001 A1	1/2009	Morin et al.	
		2009/0007188 A1	1/2009	Omernick	
		2009/0011709 A1	1/2009	Akasaka et al.	
		2009/0012748 A1	1/2009	Beish et al.	
		2009/0012775 A1	1/2009	El Hady et al.	
		2009/0018828 A1	1/2009	Nakadai et al.	
		2009/0018829 A1	1/2009	Kuperstein	
		2009/0018834 A1	1/2009	Cooper et al.	
		2009/0018835 A1	1/2009	Cooper et al.	
		2009/0018839 A1	1/2009	Cooper et al.	
		2009/0018840 A1	1/2009	Lutz et al.	
		2009/0022329 A1	1/2009	Mahowald	
		2009/0024595 A1	1/2009	Chen	
		2009/0027334 A1	1/2009	Foult et al.	
		2009/0028435 A1	1/2009	Wu et al.	
		2009/0030685 A1	1/2009	Cerra et al.	
		2009/0030800 A1	1/2009	Grois	
		2009/0030978 A1	1/2009	Johnson et al.	
		2009/0043580 A1	2/2009	Mozer et al.	
		2009/0043583 A1	2/2009	Agapi et al.	
		2009/0043763 A1	2/2009	Peng	
		2009/0044094 A1	2/2009	Rapp et al.	
		2009/0048821 A1	2/2009	Yam et al.	
		2009/0048841 A1	2/2009	Pollet et al.	
		2009/0048845 A1	2/2009	Burckart et al.	
		2009/0049067 A1	2/2009	Murray	
		2009/0051649 A1	2/2009	Rondel et al.	
		2009/0055168 A1	2/2009	Wu et al.	
		2009/0055175 A1	2/2009	Terrell et al.	
		2009/0055179 A1	2/2009	Cho et al.	
		2009/0055186 A1	2/2009	Lance et al.	
		2009/0055187 A1	2/2009	Leventhal et al.	
		2009/0055380 A1	2/2009	Peng et al.	
		2009/0055381 A1	2/2009	Wu et al.	
		2009/0055648 A1	2/2009	Kim et al.	
		2009/0058823 A1	3/2009	Kocienda	
		2009/0058860 A1	3/2009	Fong et al.	
		2009/0060351 A1	3/2009	Li et al.	
		2009/0060472 A1	3/2009	Bull et al.	
		2009/0063974 A1	3/2009	Bull et al.	
		2009/0064031 A1	3/2009	Bull et al.	
		2009/0070097 A1	3/2009	Wu et al.	
		2009/0070102 A1	3/2009	Maegawa	
		2009/0070109 A1	3/2009	Didcock et al.	
		2009/0070114 A1	3/2009	Staszak	
		2009/0074214 A1	3/2009	Bradford et al.	
		2009/0076792 A1	3/2009	Lawson-Tancred	
		2009/0076796 A1	3/2009	Daraselia	
		2009/0076798 A1	3/2009	Oh et al.	
		2009/0076819 A1	3/2009	Wouters et al.	
		2009/0076821 A1	3/2009	Brenner et al.	
		2009/0076825 A1	3/2009	Bradford et al.	
		2009/0077047 A1	3/2009	Cooper et al.	
		2009/0077165 A1	3/2009	Rhodes et al.	
		2009/0077464 A1	3/2009	Goldsmith et al.	
		2009/0079622 A1	3/2009	Seshadri et al.	
		2009/0083034 A1	3/2009	Hernandez et al.	
		2009/0083035 A1	3/2009	Huang et al.	
		2009/0083036 A1	3/2009	Zhao et al.	
		2009/0083037 A1	3/2009	Gleason et al.	

(56)

References Cited

U.S. PATENT DOCUMENTS

2009/0083047	A1	3/2009	Lindahl et al.	2009/0182445	A1	7/2009	Girish et al.
2009/0089058	A1	4/2009	Bellegarda	2009/0182549	A1	7/2009	Anisimovich et al.
2009/0091537	A1	4/2009	Huang et al.	2009/0182702	A1	7/2009	Miller
2009/0092239	A1	4/2009	Macwan et al.	2009/0183070	A1	7/2009	Robbins
2009/0092260	A1	4/2009	Powers	2009/0187402	A1	7/2009	Scholl
2009/0092261	A1	4/2009	Bard	2009/0187577	A1	7/2009	Reznik et al.
2009/0092262	A1	4/2009	Costa et al.	2009/0187950	A1	7/2009	Nicas et al.
2009/0094029	A1	4/2009	Koch et al.	2009/0190774	A1	7/2009	Wang et al.
2009/0094033	A1	4/2009	Mozer et al.	2009/0191895	A1	7/2009	Singh et al.
2009/0097634	A1	4/2009	Nambiar et al.	2009/0192782	A1	7/2009	Drewes
2009/0097637	A1	4/2009	Boscher et al.	2009/0192787	A1	7/2009	Roon
2009/0098903	A1	4/2009	Donaldson et al.	2009/0192798	A1	7/2009	Basson et al.
2009/0100049	A1	4/2009	Cao	2009/0198497	A1	8/2009	Kwon
2009/0100454	A1	4/2009	Weber	2009/0204402	A1	8/2009	Marhawa et al.
2009/0104898	A1	4/2009	Harris	2009/0204409	A1	8/2009	Mozer et al.
2009/0106026	A1	4/2009	Ferrieux	2009/0204478	A1	8/2009	Kaib et al.
2009/0106376	A1	4/2009	Tom et al.	2009/0204596	A1	8/2009	Brun et al.
2009/0106397	A1	4/2009	O'Keefe	2009/0204601	A1	8/2009	Grasset
2009/0112572	A1	4/2009	Thorn	2009/0204620	A1	8/2009	Thione et al.
2009/0112576	A1	4/2009	Jackson et al.	2009/0210230	A1	8/2009	Schwarz et al.
2009/0112592	A1	4/2009	Candelore et al.	2009/0210232	A1	8/2009	Sanchez et al.
2009/0112596	A1	4/2009	Syrdal et al.	2009/0213134	A1	8/2009	Stephanick et al.
2009/0112677	A1	4/2009	Rhett	2009/0215466	A1	8/2009	Ahl et al.
2009/0112892	A1	4/2009	Cardie et al.	2009/0215503	A1	8/2009	Zhang et al.
2009/0119587	A1	5/2009	Allen et al.	2009/0216396	A1	8/2009	Yamagata
2009/0123021	A1	5/2009	Jung et al.	2009/0216528	A1	8/2009	Gemello et al.
2009/0123071	A1	5/2009	Iwasaki	2009/0216540	A1	8/2009	Tessel et al.
2009/0125299	A1	5/2009	Wang	2009/0216704	A1	8/2009	Zheng et al.
2009/0125477	A1	5/2009	Lu et al.	2009/0219166	A1	9/2009	MacFarlane et al.
2009/0125602	A1	5/2009	Bhatia et al.	2009/0221274	A1	9/2009	Venkatakrishnan et al.
2009/0125813	A1	5/2009	Shen et al.	2009/0222257	A1	9/2009	Sumita et al.
2009/0125947	A1	5/2009	Ibaraki	2009/0222270	A2	9/2009	Likens et al.
2009/0128505	A1	5/2009	Partridge et al.	2009/0222488	A1	9/2009	Boerries et al.
2009/0132253	A1	5/2009	Bellegarda	2009/0224867	A1	9/2009	O'Shaughnessy et al.
2009/0132255	A1	5/2009	Lu	2009/0228126	A1	9/2009	Spielberg et al.
2009/0137286	A1	5/2009	Luke et al.	2009/0228273	A1	9/2009	Wang et al.
2009/0138263	A1	5/2009	Shozakai et al.	2009/0228277	A1	9/2009	Bonforte et al.
2009/0138430	A1	5/2009	Nambiar et al.	2009/0228281	A1	9/2009	Singleton et al.
2009/0138736	A1	5/2009	Chin	2009/0228439	A1	9/2009	Manolescu et al.
2009/0138828	A1	5/2009	Schultz et al.	2009/0228792	A1	9/2009	Van Os et al.
2009/0144036	A1	6/2009	Jorgensen et al.	2009/0228842	A1	9/2009	Westerman et al.
2009/0144049	A1	6/2009	Haddad et al.	2009/0233264	A1	9/2009	Rogers et al.
2009/0144428	A1	6/2009	Bowater et al.	2009/0234638	A1	9/2009	Ranjan et al.
2009/0144609	A1	6/2009	Liang et al.	2009/0234651	A1	9/2009	Basir et al.
2009/0146848	A1	6/2009	Ghassabian	2009/0234655	A1	9/2009	Kwon
2009/0150147	A1	6/2009	Jacoby et al.	2009/0235280	A1	9/2009	Tannier et al.
2009/0150156	A1	6/2009	Kennewick et al.	2009/0239202	A1	9/2009	Stone
2009/0152349	A1	6/2009	Bonev et al.	2009/0239552	A1	9/2009	Churchill et al.
2009/0153288	A1	6/2009	Hope et al.	2009/0240485	A1	9/2009	Dalal et al.
2009/0154669	A1	6/2009	Wood et al.	2009/0241054	A1	9/2009	Hendricks
2009/0157382	A1	6/2009	Bar	2009/0241760	A1	10/2009	Georges
2009/0157384	A1	6/2009	Toutanova et al.	2009/0247237	A1	10/2009	Mittleman et al.
2009/0157401	A1	6/2009	Bennett	2009/0248182	A1	10/2009	Logan et al.
2009/0158200	A1	6/2009	Palahnuk et al.	2009/0248395	A1	10/2009	Alewine et al.
2009/0158323	A1	6/2009	Bober et al.	2009/0248402	A1	10/2009	Ito et al.
2009/0158423	A1	6/2009	Orlassino et al.	2009/0248420	A1	10/2009	Basir et al.
2009/0160761	A1	6/2009	Moosavi et al.	2009/0248422	A1	10/2009	Li et al.
2009/0160803	A1	6/2009	Hashimoto	2009/0248456	A1	10/2009	Fahmy et al.
2009/0163243	A1	6/2009	Barbera	2009/0249198	A1	10/2009	Davis et al.
2009/0164301	A1	6/2009	O'Sullivan et al.	2009/0249247	A1	10/2009	Tseng et al.
2009/0164441	A1	6/2009	Cheyser	2009/0252350	A1	10/2009	Seguin
2009/0164655	A1	6/2009	Pettersson et al.	2009/0253457	A1	10/2009	Seguin
2009/0164937	A1	6/2009	Alviar et al.	2009/0253463	A1	10/2009	Shin et al.
2009/0167508	A1	7/2009	Fadell et al.	2009/0254339	A1	10/2009	Seguin
2009/0167509	A1	7/2009	Fadell et al.	2009/0254345	A1	10/2009	Fleizach et al.
2009/0171578	A1	7/2009	Kim et al.	2009/0254819	A1	10/2009	Song et al.
2009/0171662	A1	7/2009	Huang et al.	2009/0254823	A1	10/2009	Barrett
2009/0171664	A1	7/2009	Kennewick et al.	2009/0259472	A1	10/2009	Schroeter
2009/0172108	A1	7/2009	Singh	2009/0259475	A1	10/2009	Yamagami et al.
2009/0172542	A1	7/2009	Girish et al.	2009/0259969	A1	10/2009	Pallakoff
2009/0174667	A1	7/2009	Kocienda et al.	2009/0265171	A1	10/2009	Davis
2009/0174677	A1	7/2009	Gehani et al.	2009/0265368	A1	10/2009	Crider et al.
2009/0177300	A1	7/2009	Lee	2009/0271109	A1	10/2009	Lee et al.
2009/0177461	A1	7/2009	Ehsani et al.	2009/0271175	A1	10/2009	Bodin et al.
2009/0177966	A1	7/2009	Chaudhri	2009/0271176	A1	10/2009	Bodin et al.
				2009/0271178	A1	10/2009	Bodin et al.
				2009/0271188	A1	10/2009	Agapi et al.
				2009/0271189	A1	10/2009	Agapi et al.
				2009/0274315	A1	11/2009	Carnes et al.

(56)

References Cited

U.S. PATENT DOCUMENTS

2009/0274376	A1	11/2009	Selvaraj et al.	2010/0037183	A1	2/2010	Miyashita et al.
2009/0278804	A1	11/2009	Rubanovich et al.	2010/0037187	A1	2/2010	Kondziela
2009/0281789	A1	11/2009	Waibel et al.	2010/0042400	A1	2/2010	Block et al.
2009/0284471	A1	11/2009	Longe et al.	2010/0042576	A1	2/2010	Roettger et al.
2009/0284482	A1	11/2009	Chin	2010/0046842	A1	2/2010	Conwell et al.
2009/0286514	A1	11/2009	Lichorowic et al.	2010/0049498	A1	2/2010	Cao et al.
2009/0287583	A1	11/2009	Holmes	2010/0049514	A1	2/2010	Kennewick et al.
2009/0290718	A1	11/2009	Kahn et al.	2010/0050064	A1	2/2010	Liu et al.
2009/0292987	A1	11/2009	Sorenson	2010/0054512	A1	3/2010	Solum
2009/0296552	A1	12/2009	Hicks et al.	2010/0057435	A1	3/2010	Kent et al.
2009/0298474	A1	12/2009	George	2010/0057443	A1	3/2010	Di Cristo et al.
2009/0298529	A1	12/2009	Mahajan	2010/0057457	A1	3/2010	Ogata et al.
2009/0299730	A1	12/2009	Joh et al.	2010/0057461	A1	3/2010	Neubacher et al.
2009/0299745	A1	12/2009	Kennewick et al.	2010/0057643	A1	3/2010	Yang
2009/0299751	A1	12/2009	Jung	2010/0058200	A1	3/2010	Jablokov et al.
2009/0299849	A1	12/2009	Cao et al.	2010/0060646	A1	3/2010	Unsal et al.
2009/0300391	A1	12/2009	Jessup et al.	2010/0063804	A1	3/2010	Sato et al.
2009/0300488	A1	12/2009	Salamon et al.	2010/0063825	A1	3/2010	Williams et al.
2009/0304198	A1	12/2009	Herre et al.	2010/0063961	A1	3/2010	Guiheneuf et al.
2009/0305203	A1	12/2009	Okumura et al.	2010/0064113	A1	3/2010	Lindahl et al.
2009/0306967	A1	12/2009	Nicolov et al.	2010/0064218	A1	3/2010	Bull et al.
2009/0306969	A1	12/2009	Goud et al.	2010/0064226	A1	3/2010	Stefaniak et al.
2009/0306979	A1	12/2009	Jaiswal et al.	2010/0066546	A1	3/2010	Aaron
2009/0306980	A1	12/2009	Shin	2010/0066684	A1	3/2010	Shahraray et al.
2009/0306981	A1	12/2009	Cromack et al.	2010/0067723	A1	3/2010	Bergmann et al.
2009/0306985	A1	12/2009	Roberts et al.	2010/0067867	A1	3/2010	Lin et al.
2009/0306988	A1	12/2009	Chen et al.	2010/0070281	A1	3/2010	Conkie et al.
2009/0306989	A1	12/2009	Kaji	2010/0070517	A1	3/2010	Ghosh et al.
2009/0307162	A1	12/2009	Bui et al.	2010/0070521	A1	3/2010	Clinchant et al.
2009/0307201	A1	12/2009	Dunning et al.	2010/0070899	A1	3/2010	Hunt et al.
2009/0307584	A1	12/2009	Davidson et al.	2010/0071003	A1	3/2010	Bychkov et al.
2009/0307594	A1	12/2009	Kosonen et al.	2010/0076760	A1	3/2010	Kraenzel et al.
2009/0309352	A1	12/2009	Walker et al.	2010/0076993	A1	3/2010	Klawitter et al.
2009/0313014	A1	12/2009	Shin et al.	2010/0077350	A1	3/2010	Lim et al.
2009/0313020	A1	12/2009	Koivunen	2010/0079501	A1	4/2010	Ikeda et al.
2009/0313023	A1	12/2009	Jones	2010/0079508	A1	4/2010	Hodge et al.
2009/0313026	A1	12/2009	Coffman et al.	2010/0080398	A1	4/2010	Waldmann
2009/0313544	A1	12/2009	Wood et al.	2010/0080470	A1	4/2010	Deluca et al.
2009/0313564	A1	12/2009	Rottler et al.	2010/0081456	A1	4/2010	Singh et al.
2009/0316943	A1	12/2009	Frigola Munoz et al.	2010/0081487	A1	4/2010	Chen et al.
2009/0318119	A1	12/2009	Basir et al.	2010/0082286	A1	4/2010	Leung
2009/0318198	A1	12/2009	Carroll	2010/0082327	A1	4/2010	Rogers et al.
2009/0319257	A1	12/2009	Blume et al.	2010/0082328	A1	4/2010	Rogers et al.
2009/0319266	A1	12/2009	Brown et al.	2010/0082329	A1	4/2010	Silverman et al.
2009/0319342	A1	12/2009	Shilman et al.	2010/0082333	A1	4/2010	Al-Shammari
2009/0326923	A1	12/2009	Yan et al.	2010/0082343	A1	4/2010	Levit et al.
2009/0326936	A1	12/2009	Nagashima	2010/0082346	A1	4/2010	Rogers et al.
2009/0326938	A1	12/2009	Marila et al.	2010/0082347	A1	4/2010	Rogers et al.
2009/0326949	A1	12/2009	Douthitt et al.	2010/0082348	A1	4/2010	Silverman et al.
2009/0327977	A1	12/2009	Bachfischer et al.	2010/0082349	A1	4/2010	Bellegarda et al.
2010/0004918	A1	1/2010	Lee et al.	2010/0082376	A1	4/2010	Levitt
2010/0004930	A1	1/2010	Strope et al.	2010/0082567	A1	4/2010	Rosenblatt et al.
2010/0004931	A1	1/2010	Ma et al.	2010/0082970	A1	4/2010	Lindahl et al.
2010/0005081	A1	1/2010	Bennett	2010/0086152	A1	4/2010	Rank et al.
2010/0010803	A1	1/2010	Ishikawa et al.	2010/0086153	A1	4/2010	Hagen et al.
2010/0010814	A1	1/2010	Patel	2010/0086156	A1	4/2010	Rank et al.
2010/0010948	A1	1/2010	Ito et al.	2010/0088020	A1	4/2010	Sano et al.
2010/0013760	A1	1/2010	Hirai et al.	2010/0088093	A1	4/2010	Lee et al.
2010/0013796	A1	1/2010	Abileah et al.	2010/0088100	A1	4/2010	Lindahl
2010/0017212	A1	1/2010	Attwater et al.	2010/0094632	A1	4/2010	Davis et al.
2010/0017382	A1	1/2010	Katragadda et al.	2010/0098231	A1	4/2010	Wohlert et al.
2010/0019834	A1	1/2010	Zerbe et al.	2010/0100212	A1	4/2010	Lindahl et al.
2010/0020035	A1	1/2010	Ryu et al.	2010/0100384	A1	4/2010	Ju et al.
2010/0023318	A1	1/2010	Lemoine	2010/0100385	A1	4/2010	Davis et al.
2010/0023320	A1	1/2010	Di Cristo et al.	2010/0100515	A1	4/2010	Bangalore et al.
2010/0023331	A1	1/2010	Duta et al.	2010/0100816	A1	4/2010	McCloskey et al.
2010/0026526	A1	2/2010	Yokota	2010/0103776	A1	4/2010	Chan
2010/0030549	A1	2/2010	Lee et al.	2010/0106486	A1	4/2010	Hua et al.
2010/0030928	A1	2/2010	Conroy et al.	2010/0106498	A1	4/2010	Morrison et al.
2010/0031143	A1	2/2010	Rao et al.	2010/0106500	A1	4/2010	McKee et al.
2010/0036653	A1	2/2010	Kim et al.	2010/0106503	A1	4/2010	Farrell et al.
2010/0036655	A1	2/2010	Cecil et al.	2010/0114856	A1	5/2010	Kuboyama
2010/0036660	A1	2/2010	Bennett	2010/0114887	A1	5/2010	Conway et al.
2010/0036829	A1	2/2010	Leyba	2010/0121637	A1	5/2010	Roy et al.
2010/0036928	A1	2/2010	Granito et al.	2010/0125456	A1	5/2010	Weng et al.
				2010/0125458	A1	5/2010	Franco et al.
				2010/0125460	A1	5/2010	Mellott et al.
				2010/0125811	A1	5/2010	Moore et al.
				2010/0128701	A1	5/2010	Nagaraja

(56)		References Cited	
U.S. PATENT DOCUMENTS			
2010/0131265	A1	5/2010	Boda et al.
2010/0131269	A1	5/2010	Park et al.
2010/0131273	A1	5/2010	Aley-Raz et al.
2010/0131498	A1	5/2010	Linthicum et al.
2010/0131899	A1	5/2010	Hubert
2010/0138215	A1	6/2010	Williams
2010/0138224	A1	6/2010	Bedingfield, Sr.
2010/0138416	A1	6/2010	Bellotti
2010/0138680	A1	6/2010	Brisebois et al.
2010/0138759	A1	6/2010	Roy
2010/0138798	A1	6/2010	Wilson et al.
2010/0142740	A1	6/2010	Roerup
2010/0145694	A1	6/2010	Ju et al.
2010/0145700	A1	6/2010	Kennewick et al.
2010/0145707	A1	6/2010	Ljolje et al.
2010/0146442	A1	6/2010	Nagasaka et al.
2010/0150321	A1	6/2010	Harris et al.
2010/0153114	A1	6/2010	Shih et al.
2010/0153115	A1	6/2010	Klee et al.
2010/0153448	A1	6/2010	Harpur et al.
2010/0153576	A1	6/2010	Wohlert et al.
2010/0161311	A1	6/2010	Massuh
2010/0161313	A1	6/2010	Karttunen
2010/0161337	A1	6/2010	Pulz et al.
2010/0161554	A1	6/2010	Datuashvili et al.
2010/0164897	A1	7/2010	Morin et al.
2010/0169075	A1	7/2010	Raffa et al.
2010/0169093	A1	7/2010	Washio
2010/0169097	A1	7/2010	Nachman et al.
2010/0169098	A1	7/2010	Patch
2010/0171713	A1	7/2010	Kwok et al.
2010/0174544	A1	7/2010	Heifets
2010/0175066	A1	7/2010	Paik
2010/0179932	A1	7/2010	Yoon et al.
2010/0179991	A1	7/2010	Lorch et al.
2010/0180218	A1	7/2010	Boston et al.
2010/0185448	A1	7/2010	Meisel
2010/0185949	A1	7/2010	Jaeger
2010/0191520	A1	7/2010	Gruhn et al.
2010/0197359	A1	8/2010	Harris
2010/0198821	A1	8/2010	Loritz et al.
2010/0199180	A1	8/2010	Brichter et al.
2010/0199215	A1	8/2010	Seymour et al.
2010/0204986	A1	8/2010	Kennewick et al.
2010/0211199	A1	8/2010	Naik et al.
2010/0211379	A1	8/2010	Gorman et al.
2010/0211644	A1	8/2010	Lavoie et al.
2010/0216509	A1	8/2010	Riemer et al.
2010/0217604	A1	8/2010	Baldwin et al.
2010/0222033	A1	9/2010	Scott et al.
2010/0222098	A1	9/2010	Garg
2010/0223055	A1	9/2010	Mclean
2010/0223056	A1	9/2010	Kadiramanathan et al.
2010/0223131	A1	9/2010	Scott et al.
2010/0225599	A1	9/2010	Danielsson et al.
2010/0225809	A1	9/2010	Connors et al.
2010/0227642	A1	9/2010	Kim et al.
2010/0228540	A1	9/2010	Bennett
2010/0228549	A1	9/2010	Herman et al.
2010/0228691	A1	9/2010	Yang et al.
2010/0229082	A1	9/2010	Karmarkar et al.
2010/0229100	A1	9/2010	Miller et al.
2010/0231474	A1	9/2010	Yamagajo et al.
2010/0235167	A1	9/2010	Bourdon
2010/0235341	A1	9/2010	Bennett
2010/0235729	A1	9/2010	Kocienda et al.
2010/0235732	A1	9/2010	Bergman
2010/0235770	A1	9/2010	Ording et al.
2010/0235780	A1	9/2010	Westerman et al.
2010/0241418	A1	9/2010	Maeda et al.
2010/0250542	A1	9/2010	Fujimaki
2010/0250599	A1	9/2010	Schmidt et al.
2010/0255858	A1	10/2010	Juhasz
2010/0257160	A1	10/2010	Cao
2010/0257478	A1	10/2010	Longe et al.
2010/0257490	A1	10/2010	Lyon et al.
2010/0262599	A1	10/2010	Nitz
2010/0263015	A1	10/2010	Pandey et al.
2010/0268537	A1	10/2010	Al-Telmissani
2010/0268539	A1	10/2010	Xu et al.
2010/0269040	A1	10/2010	Lee
2010/0274753	A1	10/2010	Liberty et al.
2010/0277579	A1	11/2010	Cho et al.
2010/0278320	A1	11/2010	Arsenault et al.
2010/0278391	A1	11/2010	Hsu et al.
2010/0278453	A1	11/2010	King
2010/0280983	A1	11/2010	Cho et al.
2010/0281034	A1	11/2010	Petrou et al.
2010/0286984	A1	11/2010	Wandinger et al.
2010/0286985	A1	11/2010	Kennewick et al.
2010/0287514	A1	11/2010	Cragun et al.
2010/0290632	A1	11/2010	Lin
2010/0293460	A1	11/2010	Budelli
2010/0295645	A1	11/2010	Falldin et al.
2010/0299133	A1	11/2010	Kopparapu et al.
2010/0299138	A1	11/2010	Kim
2010/0299142	A1	11/2010	Freeman et al.
2010/0302056	A1	12/2010	Dutton et al.
2010/0304342	A1	12/2010	Zilber
2010/0304705	A1	12/2010	Hursey et al.
2010/0305807	A1	12/2010	Basir et al.
2010/0305947	A1	12/2010	Schwarz et al.
2010/0312547	A1	12/2010	Van Os et al.
2010/0312566	A1	12/2010	Odinak et al.
2010/0318366	A1	12/2010	Sullivan et al.
2010/0318576	A1	12/2010	Kim
2010/0322438	A1	12/2010	Siotis
2010/0324709	A1	12/2010	Starmen
2010/0324895	A1	12/2010	Kurzweil et al.
2010/0324896	A1	12/2010	Attwater et al.
2010/0324905	A1	12/2010	Kurzweil et al.
2010/0325131	A1	12/2010	Dumais et al.
2010/0325158	A1	12/2010	Oral et al.
2010/0325573	A1	12/2010	Estrada et al.
2010/0325588	A1	12/2010	Reddy et al.
2010/0330908	A1	12/2010	Maddern et al.
2010/0332003	A1	12/2010	Yaguez
2010/0332220	A1	12/2010	Hursey et al.
2010/0332224	A1	12/2010	Mäkeläet al.
2010/0332235	A1	12/2010	David
2010/0332236	A1	12/2010	Tan
2010/0332280	A1	12/2010	Bradley et al.
2010/0332348	A1	12/2010	Cao
2010/0332428	A1	12/2010	Mchenry et al.
2010/0332976	A1	12/2010	Fux et al.
2010/0333030	A1	12/2010	Johns
2010/0333163	A1	12/2010	Daly
2011/0002487	A1	1/2011	Panther et al.
2011/0004475	A1	1/2011	Bellegarda
2011/0006876	A1	1/2011	Moberg et al.
2011/0009107	A1	1/2011	Guba et al.
2011/0010178	A1	1/2011	Lee et al.
2011/0010644	A1	1/2011	Merrill et al.
2011/0015928	A1	1/2011	Odell et al.
2011/0016150	A1	1/2011	Engstrom et al.
2011/0016421	A1	1/2011	Krupka et al.
2011/0018695	A1	1/2011	Bells et al.
2011/0021211	A1	1/2011	Ohki
2011/0021213	A1	1/2011	Carr
2011/0022292	A1	1/2011	Shen et al.
2011/0022388	A1	1/2011	Wu et al.
2011/0022393	A1	1/2011	Waller et al.
2011/0022394	A1	1/2011	Wide et al.
2011/0022472	A1	1/2011	Zon et al.
2011/0022952	A1	1/2011	Wu et al.
2011/0029616	A1	2/2011	Wang et al.
2011/0030067	A1	2/2011	Wilson
2011/0033064	A1	2/2011	Johnson et al.
2011/0034183	A1	2/2011	Haag et al.
2011/0035144	A1	2/2011	Okamoto et al.
2011/0035434	A1	2/2011	Lockwood
2011/0038489	A1	2/2011	Visser et al.
2011/0039584	A1	2/2011	Merrett
2011/0040707	A1	2/2011	Theisen et al.

(56)

References Cited

U.S. PATENT DOCUMENTS

2011/0045841	A1	2/2011	Kuhlke et al.	2011/0151830	A1	6/2011	Blanda et al.
2011/0047072	A1	2/2011	Ciurea	2011/0153209	A1	6/2011	Geelen
2011/0047149	A1	2/2011	Vaananen	2011/0153322	A1	6/2011	Kwak et al.
2011/0047161	A1	2/2011	Myaeng et al.	2011/0153324	A1	6/2011	Ballinger et al.
2011/0047266	A1	2/2011	Yu et al.	2011/0153329	A1	6/2011	Moorer
2011/0047605	A1	2/2011	Sontag et al.	2011/0153330	A1	6/2011	Yazdani et al.
2011/0050591	A1	3/2011	Kim et al.	2011/0153373	A1	6/2011	Dantzig et al.
2011/0050592	A1	3/2011	Kim et al.	2011/0154193	A1	6/2011	Creutz et al.
2011/0054647	A1	3/2011	Chipchase	2011/0157029	A1	6/2011	Tseng
2011/0054894	A1	3/2011	Phillips et al.	2011/0161072	A1	6/2011	Terao et al.
2011/0054901	A1	3/2011	Qin et al.	2011/0161076	A1	6/2011	Davis et al.
2011/0055256	A1	3/2011	Phillips et al.	2011/0161079	A1	6/2011	Gruhn et al.
2011/0060584	A1	3/2011	Ferrucci et al.	2011/0161309	A1	6/2011	Lung et al.
2011/0060587	A1	3/2011	Phillips et al.	2011/0161852	A1	6/2011	Vainio et al.
2011/0060589	A1	3/2011	Weinberg et al.	2011/0166851	A1	7/2011	LeBeau et al.
2011/0060807	A1	3/2011	Martin et al.	2011/0166855	A1	7/2011	Vermeulen et al.
2011/0060812	A1	3/2011	Middleton	2011/0167350	A1	7/2011	Hoellwarth
2011/0064387	A1	3/2011	Mendeloff et al.	2011/0175810	A1	7/2011	Markovic et al.
2011/0065456	A1	3/2011	Brennan et al.	2011/0178804	A1	7/2011	Inoue et al.
2011/0066366	A1	3/2011	Ellanti et al.	2011/0179002	A1	7/2011	Dumitru et al.
2011/0066436	A1	3/2011	Bezar	2011/0179372	A1	7/2011	Moore et al.
2011/0066468	A1	3/2011	Huang et al.	2011/0183627	A1	7/2011	Ueda et al.
2011/0066634	A1	3/2011	Phillips et al.	2011/0183650	A1	7/2011	Mckee et al.
2011/0072033	A1	3/2011	White et al.	2011/0184721	A1	7/2011	Subramanian et al.
2011/0072492	A1	3/2011	Mohler et al.	2011/0184730	A1	7/2011	LeBeau et al.
2011/0076994	A1	3/2011	Kim et al.	2011/0184736	A1	7/2011	Slotznick
2011/0077943	A1	3/2011	Miki et al.	2011/0184737	A1	7/2011	Nakano et al.
2011/0080260	A1	4/2011	Wang et al.	2011/0184768	A1	7/2011	Norton et al.
2011/0081889	A1	4/2011	Gao et al.	2011/0185288	A1	7/2011	Gupta et al.
2011/0082688	A1	4/2011	Kim et al.	2011/0191108	A1	8/2011	Friedlander
2011/0083079	A1	4/2011	Farrell et al.	2011/0191271	A1	8/2011	Baker et al.
2011/0087491	A1	4/2011	Wittenstein et al.	2011/0191344	A1	8/2011	Jin et al.
2011/0087685	A1	4/2011	Lin et al.	2011/0195758	A1	8/2011	Damale et al.
2011/0090078	A1	4/2011	Kim et al.	2011/0196670	A1	8/2011	Dang et al.
2011/0092187	A1	4/2011	Miller	2011/0197128	A1	8/2011	Assadollahi et al.
2011/0093261	A1	4/2011	Angott	2011/0199312	A1	8/2011	Okuta
2011/0093271	A1	4/2011	Stent et al.	2011/0201385	A1	8/2011	Higginbotham et al.
2011/0093272	A1	4/2011	Bernard et al.	2011/0201387	A1	8/2011	Paek et al.
2011/0093272	A1	4/2011	Isobe et al.	2011/0202526	A1	8/2011	Lee et al.
2011/0099000	A1	4/2011	Rai et al.	2011/0205149	A1	8/2011	Tom et al.
2011/0099157	A1	4/2011	Lebeau et al.	2011/0208511	A1	8/2011	Sikstrom et al.
2011/0103682	A1	5/2011	Chidlovskii et al.	2011/0208524	A1	8/2011	Haughay
2011/0105097	A1	5/2011	Tadayon et al.	2011/0209088	A1	8/2011	Hinckley et al.
2011/0106736	A1	5/2011	Aharonson et al.	2011/0212717	A1	9/2011	Rhoads et al.
2011/0106892	A1	5/2011	Nelson et al.	2011/0216093	A1	9/2011	Griffin
2011/0110502	A1	5/2011	Daye et al.	2011/0218806	A1	9/2011	Alewine et al.
2011/0111724	A1	5/2011	Baptiste	2011/0218855	A1	9/2011	Cao et al.
2011/0112825	A1	5/2011	Bellegarda	2011/0219018	A1	9/2011	Bailey et al.
2011/0112827	A1	5/2011	Kennewick et al.	2011/0223893	A1	9/2011	Lau et al.
2011/0112837	A1	5/2011	Kurki-Suonio et al.	2011/0224972	A1	9/2011	Millett et al.
2011/0112838	A1	5/2011	Adibi	2011/0228913	A1	9/2011	Cochinwala et al.
2011/0112921	A1	5/2011	Kennewick et al.	2011/0231182	A1	9/2011	Weider et al.
2011/0116610	A1	5/2011	Shaw et al.	2011/0231184	A1	9/2011	Kerr
2011/0119049	A1	5/2011	Ylonen	2011/0231188	A1	9/2011	Kennewick et al.
2011/0119051	A1	5/2011	Li et al.	2011/0231218	A1	9/2011	Tovar
2011/0119623	A1	5/2011	Kim	2011/0231432	A1	9/2011	Sata et al.
2011/0119715	A1	5/2011	Chang et al.	2011/0231474	A1	9/2011	Locker et al.
2011/0123004	A1	5/2011	Chang et al.	2011/0238191	A1	9/2011	Kristjansson et al.
2011/0125498	A1	5/2011	Pickering et al.	2011/0238407	A1	9/2011	Kent
2011/0125540	A1	5/2011	Jang et al.	2011/0238408	A1	9/2011	Larcheveque et al.
2011/0125701	A1	5/2011	Nair et al.	2011/0238676	A1	9/2011	Liu et al.
2011/0130958	A1	6/2011	Stahl et al.	2011/0239111	A1	9/2011	Grover
2011/0131036	A1	6/2011	DiCristo et al.	2011/0242007	A1	10/2011	Gray et al.
2011/0131038	A1	6/2011	Oyaizu et al.	2011/0244888	A1	10/2011	Ohki
2011/0131045	A1	6/2011	Cristo et al.	2011/0246471	A1	10/2011	Rakib et al.
2011/0137636	A1	6/2011	Srihari et al.	2011/0249144	A1	10/2011	Chang
2011/0137664	A1	6/2011	Kho et al.	2011/0250570	A1	10/2011	Mack et al.
2011/0141141	A1	6/2011	Kankainen	2011/0257966	A1	10/2011	Rychlik
2011/0143726	A1	6/2011	de Silva	2011/0258188	A1	10/2011	Abdalmageed et al.
2011/0143811	A1	6/2011	Rodriguez	2011/0260829	A1	10/2011	Lee
2011/0144857	A1	6/2011	Wingrove et al.	2011/0260861	A1	10/2011	Singh et al.
2011/0144901	A1	6/2011	Wang	2011/0264643	A1	10/2011	Cao
2011/0144973	A1	6/2011	Bocchieri et al.	2011/0264999	A1	10/2011	Bells et al.
2011/0144999	A1	6/2011	Jang et al.	2011/0274303	A1	11/2011	Filson et al.
2011/0145718	A1	6/2011	Ketola et al.	2011/0276595	A1	11/2011	Kirkland et al.
				2011/0276598	A1	11/2011	Kozempel
				2011/0276944	A1	11/2011	Bergman et al.
				2011/0279368	A1	11/2011	Klein et al.
				2011/0280143	A1	11/2011	Li et al.

(56)		References Cited					
		U.S. PATENT DOCUMENTS					
2011/0282663	A1	11/2011	Talwar et al.	2012/0066212	A1	3/2012	Jennings
2011/0282888	A1	11/2011	Koperski et al.	2012/0066581	A1	3/2012	Spalink
2011/0282906	A1	11/2011	Wong	2012/0075054	A1	3/2012	Ge et al.
2011/0283189	A1	11/2011	McCarty	2012/0075184	A1	3/2012	Madhvanath
2011/0283190	A1	11/2011	Poltorak	2012/0077479	A1	3/2012	Sabotta et al.
2011/0288852	A1	11/2011	Dymetman et al.	2012/0078611	A1	3/2012	Soltani et al.
2011/0288855	A1	11/2011	Roy	2012/0078624	A1	3/2012	Yook et al.
2011/0288861	A1	11/2011	Kurzweil et al.	2012/0078627	A1	3/2012	Wagner
2011/0288863	A1	11/2011	Rasmussen	2012/0078635	A1	3/2012	Rothkopf et al.
2011/0288866	A1	11/2011	Rasmussen	2012/0078747	A1	3/2012	Chakrabarti et al.
2011/0298585	A1	12/2011	Barry	2012/0082317	A1	4/2012	Pance et al.
2011/0301943	A1	12/2011	Patch	2012/0083286	A1	4/2012	Kim et al.
2011/0302162	A1	12/2011	Xiao et al.	2012/0084086	A1	4/2012	Gilbert et al.
2011/0302645	A1	12/2011	Headley	2012/0084634	A1	4/2012	Wong et al.
2011/0306426	A1	12/2011	Novak et al.	2012/0088219	A1	4/2012	Briscoe et al.
2011/0307241	A1	12/2011	Waibel et al.	2012/0089331	A1	4/2012	Schmidt et al.
2011/0307254	A1	12/2011	Hunt et al.	2012/0101823	A1	4/2012	Weng et al.
2011/0307491	A1	12/2011	Fisk et al.	2012/0108166	A1	5/2012	Hymel
2011/0307810	A1	12/2011	Hilerio et al.	2012/0108221	A1	5/2012	Thomas et al.
2011/0313775	A1	12/2011	Laligand et al.	2012/0109997	A1	5/2012	Sparks et al.
2011/0313803	A1	12/2011	Friend et al.	2012/0110456	A1	5/2012	Larco et al.
2011/0314003	A1	12/2011	Ju et al.	2012/0116770	A1	5/2012	Chen et al.
2011/0314032	A1	12/2011	Bennett et al.	2012/0117499	A1	5/2012	Mori et al.
2011/0314404	A1	12/2011	Kotler et al.	2012/0124126	A1	5/2012	Alcazar et al.
2011/0314539	A1	12/2011	Horton	2012/0124177	A1	5/2012	Sparks
2011/0320187	A1	12/2011	Motik et al.	2012/0124178	A1	5/2012	Sparks
2012/0002820	A1	1/2012	Leichter	2012/0128322	A1	5/2012	Shaffer et al.
2012/0005602	A1	1/2012	Anttila et al.	2012/0130709	A1	5/2012	Bocchieri et al.
2012/0008754	A1	1/2012	Mukherjee et al.	2012/0130972	A1*	5/2012	Ahn G06F 16/334
2012/0010886	A1	1/2012	Razavilar				707/706
2012/0011138	A1	1/2012	Dunning et al.	2012/0136572	A1	5/2012	Norton
2012/0013609	A1	1/2012	Reponen et al.	2012/0136649	A1	5/2012	Freising et al.
2012/0015629	A1	1/2012	Olsen et al.	2012/0136855	A1	5/2012	Ni et al.
2012/0016658	A1	1/2012	Wu et al.	2012/0136985	A1	5/2012	Popescu et al.
2012/0016678	A1	1/2012	Gruber et al.	2012/0137367	A1	5/2012	Dupont et al.
2012/0019400	A1	1/2012	Patel et al.	2012/0149342	A1	6/2012	Cohen et al.
2012/0020490	A1	1/2012	Leichter	2012/0149394	A1	6/2012	Singh et al.
2012/0022787	A1	1/2012	LeBeau et al.	2012/0150544	A1	6/2012	McLoughlin et al.
2012/0022857	A1	1/2012	Baldwin et al.	2012/0150580	A1	6/2012	Norton
2012/0022860	A1	1/2012	Lloyd et al.	2012/0158293	A1	6/2012	Burnham
2012/0022868	A1	1/2012	LeBeau et al.	2012/0158399	A1	6/2012	Tremblay et al.
2012/0022869	A1	1/2012	Lloyd et al.	2012/0158422	A1	6/2012	Burnham et al.
2012/0022870	A1	1/2012	Kristjansson et al.	2012/0159380	A1	6/2012	Kocienda et al.
2012/0022872	A1	1/2012	Gruber et al.	2012/0163710	A1	6/2012	Skaff et al.
2012/0022874	A1	1/2012	Lloyd et al.	2012/0166196	A1	6/2012	Ju et al.
2012/0022876	A1	1/2012	LeBeau et al.	2012/0166959	A1	6/2012	Hilerio et al.
2012/0022967	A1	1/2012	Bachman et al.	2012/0173222	A1	7/2012	Wang et al.
2012/0023088	A1	1/2012	Cheng et al.	2012/0173244	A1	7/2012	Kwak et al.
2012/0023095	A1	1/2012	Wadycki et al.	2012/0173464	A1	7/2012	Tur et al.
2012/0023462	A1	1/2012	Rosing et al.	2012/0174121	A1	7/2012	Treat et al.
2012/0029661	A1	2/2012	Jones et al.	2012/0179457	A1	7/2012	Newman et al.
2012/0029910	A1	2/2012	Medlock et al.	2012/0179467	A1	7/2012	Williams
2012/0034904	A1	2/2012	LeBeau et al.	2012/0185237	A1	7/2012	Gajic et al.
2012/0035907	A1	2/2012	Lebeau et al.	2012/0185480	A1	7/2012	Ni et al.
2012/0035908	A1	2/2012	Lebeau et al.	2012/0185781	A1	7/2012	Guzman et al.
2012/0035924	A1	2/2012	Jitkoff et al.	2012/0191461	A1	7/2012	Lin et al.
2012/0035925	A1	2/2012	Friend et al.	2012/0192096	A1	7/2012	Bowman et al.
2012/0035926	A1	2/2012	Ambler	2012/0197743	A1	8/2012	Grigg et al.
2012/0035931	A1	2/2012	LeBeau et al.	2012/0197995	A1	8/2012	Caruso
2012/0035932	A1	2/2012	Jitkoff et al.	2012/0197998	A1	8/2012	Kessel et al.
2012/0035935	A1	2/2012	Park et al.	2012/0201362	A1	8/2012	Crossan et al.
2012/0036556	A1	2/2012	LeBeau et al.	2012/0209654	A1	8/2012	Romagnino et al.
2012/0039539	A1	2/2012	Boiman et al.	2012/0209853	A1	8/2012	Desai et al.
2012/0041752	A1	2/2012	Wang et al.	2012/0209874	A1	8/2012	Wong et al.
2012/0041756	A1	2/2012	Hanazawa et al.	2012/0210266	A1	8/2012	Jiang et al.
2012/0042014	A1	2/2012	Desai et al.	2012/0214141	A1	8/2012	Raya et al.
2012/0042343	A1	2/2012	Laligand et al.	2012/0214517	A1	8/2012	Singh et al.
2012/0053815	A1	3/2012	Montanari et al.	2012/0215762	A1	8/2012	Hall et al.
2012/0053829	A1	3/2012	Agarwal et al.	2012/0221339	A1	8/2012	Wang et al.
2012/0053945	A1	3/2012	Gupta et al.	2012/0221552	A1	8/2012	Reponen et al.
2012/0056815	A1	3/2012	Mehra	2012/0223889	A1	9/2012	Medlock et al.
2012/0059655	A1	3/2012	Cartales	2012/0223936	A1	9/2012	Aughey et al.
2012/0059813	A1	3/2012	Sejnoha et al.	2012/0232885	A1	9/2012	Barbosa et al.
2012/0060052	A1	3/2012	White et al.	2012/0232886	A1	9/2012	Capuozzo et al.
2012/0062473	A1	3/2012	Xiao et al.	2012/0232906	A1	9/2012	Lindahl et al.
				2012/0233207	A1	9/2012	Mohajer
				2012/0233266	A1	9/2012	Hassan et al.
				2012/0239661	A1	9/2012	Giblin
				2012/0239761	A1	9/2012	Linner et al.

(56)

References Cited

U.S. PATENT DOCUMENTS

2012/0242482	A1	9/2012	Elumalai et al.	2013/0027875	A1	1/2013	Zhu et al.
2012/0245719	A1	9/2012	Story, Jr. et al.	2013/0030787	A1	1/2013	Cancedda et al.
2012/0245939	A1	9/2012	Braho et al.	2013/0030789	A1	1/2013	Dalce
2012/0245941	A1	9/2012	Cheyner	2013/0030804	A1	1/2013	Zavaliagko et al.
2012/0245944	A1	9/2012	Gruber et al.	2013/0030815	A1	1/2013	Madhvanath et al.
2012/0246064	A1	9/2012	Balkow	2013/0030913	A1	1/2013	Zhu et al.
2012/0250858	A1	10/2012	Iqbal et al.	2013/0030955	A1	1/2013	David
2012/0252367	A1	10/2012	Gaglio et al.	2013/0031162	A1	1/2013	Willis et al.
2012/0252540	A1	10/2012	Kirigaya	2013/0031476	A1	1/2013	Coin et al.
2012/0253785	A1	10/2012	Hamid et al.	2013/0033643	A1	2/2013	Kim et al.
2012/0253791	A1	10/2012	Heck et al.	2013/0035086	A1	2/2013	Chardon et al.
2012/0254143	A1	10/2012	Varma et al.	2013/0035942	A1	2/2013	Kim et al.
2012/0254152	A1	10/2012	Park et al.	2013/0035961	A1	2/2013	Yegnanarayanan
2012/0254290	A1	10/2012	Naaman	2013/0041647	A1	2/2013	Ramerth et al.
2012/0259615	A1	10/2012	Morin et al.	2013/0041654	A1	2/2013	Walker et al.
2012/0262296	A1	10/2012	Bezar	2013/0041661	A1	2/2013	Lee et al.
2012/0265482	A1	10/2012	Grokop et al.	2013/0041665	A1	2/2013	Jang et al.
2012/0265528	A1	10/2012	Gruber et al.	2013/0041667	A1	2/2013	Longe et al.
2012/0265535	A1	10/2012	Bryant-Rich et al.	2013/0041968	A1	2/2013	Cohen et al.
2012/0265806	A1	10/2012	Blanchflower et al.	2013/0046544	A1	2/2013	Kay et al.
2012/0271625	A1	10/2012	Bernard	2013/0050089	A1	2/2013	Neels et al.
2012/0271634	A1	10/2012	Lenke	2013/0054550	A1	2/2013	Bolohan
2012/0271635	A1	10/2012	Ljolje	2013/0054609	A1	2/2013	Rajput et al.
2012/0271640	A1	10/2012	Basir	2013/0054613	A1	2/2013	Bishop
2012/0271676	A1	10/2012	Aravamudan et al.	2013/0054631	A1	2/2013	Govani et al.
2012/0275377	A1	11/2012	Lehane et al.	2013/0054675	A1	2/2013	Jenkins et al.
2012/0278744	A1	11/2012	Kozitsyn et al.	2013/0054706	A1	2/2013	Graham et al.
2012/0284015	A1	11/2012	Drewes	2013/0055099	A1	2/2013	Yao et al.
2012/0284027	A1	11/2012	Mallett et al.	2013/0055147	A1	2/2013	Vasudev et al.
2012/0290291	A1	11/2012	Shelley et al.	2013/0063611	A1	3/2013	Papakipos et al.
2012/0290300	A1	11/2012	Lee et al.	2013/0066832	A1	3/2013	Sheehan et al.
2012/0295708	A1	11/2012	Hernandez-Abrego et al.	2013/0067307	A1	3/2013	Tian et al.
2012/0296638	A1	11/2012	Patwa	2013/0073286	A1	3/2013	Bastea-Forte et al.
2012/0296649	A1	11/2012	Bansal et al.	2013/0073346	A1	3/2013	Chun et al.
2012/0296654	A1	11/2012	Hendrickson et al.	2013/0078930	A1	3/2013	Chen et al.
2012/0296891	A1	11/2012	Rangan	2013/0080152	A1	3/2013	Brun et al.
2012/0297348	A1	11/2012	Santoro	2013/0080162	A1	3/2013	Chang et al.
2012/0303369	A1	11/2012	Brush et al.	2013/0080167	A1	3/2013	Mozer
2012/0303371	A1	11/2012	Labsky et al.	2013/0080177	A1	3/2013	Chen
2012/0304124	A1	11/2012	Chen et al.	2013/0080178	A1	3/2013	Kang et al.
2012/0309363	A1	12/2012	Gruber et al.	2013/0080251	A1	3/2013	Dempski
2012/0310642	A1	12/2012	Cao et al.	2013/0082967	A1	4/2013	Hillis et al.
2012/0310649	A1	12/2012	Cannistraro et al.	2013/0085755	A1	4/2013	Bringert et al.
2012/0310652	A1	12/2012	O'Sullivan	2013/0085761	A1	4/2013	Bringert et al.
2012/0310922	A1	12/2012	Johnson et al.	2013/0090921	A1	4/2013	Liu et al.
2012/0311478	A1	12/2012	Van Os et al.	2013/0091090	A1	4/2013	Spivack et al.
2012/0311583	A1	12/2012	Gruber et al.	2013/0095805	A1	4/2013	Lebeau et al.
2012/0311584	A1	12/2012	Gruber et al.	2013/0096909	A1	4/2013	Brun et al.
2012/0311585	A1	12/2012	Gruber et al.	2013/0096917	A1	4/2013	Edgar et al.
2012/0316862	A1	12/2012	Sultan et al.	2013/0097566	A1	4/2013	Berglund
2012/0316875	A1	12/2012	Nyquist et al.	2013/0097682	A1	4/2013	Zeljkoivic et al.
2012/0316878	A1	12/2012	Singleton et al.	2013/0100268	A1	4/2013	Mihailidis et al.
2012/0317194	A1	12/2012	Tian	2013/0103391	A1	4/2013	Millmore et al.
2012/0317498	A1	12/2012	Logan et al.	2013/0103405	A1	4/2013	Namba et al.
2012/0321112	A1	12/2012	Schubert et al.	2013/0106742	A1	5/2013	Lee et al.
2012/0324391	A1	12/2012	Tocci et al.	2013/0110505	A1	5/2013	Gruber et al.
2012/0327009	A1	12/2012	Fleizach	2013/0110515	A1	5/2013	Guzzoni et al.
2012/0329529	A1	12/2012	van der Raadt	2013/0110518	A1	5/2013	Gruber et al.
2012/0330660	A1	12/2012	Jaiswal	2013/0110519	A1	5/2013	Cheyner et al.
2012/0330661	A1	12/2012	Lindahl	2013/0110520	A1	5/2013	Cheyner et al.
2012/0330990	A1	12/2012	Chen et al.	2013/0110943	A1	5/2013	Menon et al.
2013/0002716	A1	1/2013	Walker et al.	2013/0111330	A1	5/2013	Staikos et al.
2013/0005405	A1	1/2013	Prociw	2013/0111348	A1	5/2013	Gruber et al.
2013/0006633	A1	1/2013	Grokop et al.	2013/0111365	A1	5/2013	Chen et al.
2013/0006637	A1	1/2013	Kanevsky et al.	2013/0111487	A1	5/2013	Cheyner et al.
2013/0006638	A1	1/2013	Lindahl	2013/0111581	A1	5/2013	Griffin et al.
2013/0007240	A1	1/2013	Qiu et al.	2013/0115927	A1	5/2013	Gruber et al.
2013/0007648	A1	1/2013	Gamon et al.	2013/0117022	A1	5/2013	Chen et al.
2013/0009858	A1	1/2013	Lacey	2013/0124189	A1	5/2013	Baldwin et al.
2013/0010575	A1	1/2013	He et al.	2013/0125168	A1	5/2013	Agnihotri et al.
2013/0013313	A1	1/2013	Shechtman et al.	2013/0132084	A1	5/2013	Stonehocker et al.
2013/0013319	A1	1/2013	Grant et al.	2013/0132089	A1	5/2013	Fanty et al.
2013/0014026	A1	1/2013	Beringer et al.	2013/0132871	A1	5/2013	Zeng et al.
2013/0018659	A1	1/2013	Chi	2013/0138440	A1	5/2013	Strope et al.
2013/0024576	A1	1/2013	Dishneau et al.	2013/0141551	A1	6/2013	Kim
				2013/0142317	A1	6/2013	Reynolds
				2013/0142345	A1	6/2013	Waldmann
				2013/0144594	A1	6/2013	Bangalore et al.
				2013/0144616	A1	6/2013	Bangalore et al.

(56)

References Cited

U.S. PATENT DOCUMENTS

2013/0151339	A1	6/2013	Kim et al.	2013/0311184	A1	11/2013	Badavne et al.
2013/0152092	A1	6/2013	Yadgar et al.	2013/0311997	A1	11/2013	Gruber et al.
2013/0154811	A1	6/2013	Ferren et al.	2013/0316746	A1	11/2013	Miller et al.
2013/0157629	A1	6/2013	Lee et al.	2013/0322634	A1	12/2013	Bennett et al.
2013/0158977	A1	6/2013	Senior	2013/0325436	A1	12/2013	Wang et al.
2013/0159847	A1	6/2013	Banke et al.	2013/0325443	A1	12/2013	Begeja et al.
2013/0165232	A1	6/2013	Nelson et al.	2013/0325447	A1	12/2013	Levien et al.
2013/0166303	A1	6/2013	Chang et al.	2013/0325448	A1	12/2013	Levien et al.
2013/0166442	A1	6/2013	Nakajima et al.	2013/0325481	A1	12/2013	Van Os et al.
2013/0170738	A1	7/2013	Capuozzo et al.	2013/0325484	A1	12/2013	Chakladar et al.
2013/0172022	A1	7/2013	Seymour et al.	2013/0325967	A1	12/2013	Parks et al.
2013/0173258	A1	7/2013	Liu et al.	2013/0325970	A1	12/2013	Roberts et al.
2013/0174034	A1	7/2013	Brown et al.	2013/0325979	A1	12/2013	Mansfield et al.
2013/0176244	A1	7/2013	Yamamoto et al.	2013/0328809	A1	12/2013	Smith
2013/0176592	A1	7/2013	Sasaki	2013/0329023	A1	12/2013	Suplee, III et al.
2013/0179172	A1	7/2013	Nakamura et al.	2013/0331127	A1	12/2013	Sabatelli et al.
2013/0179440	A1	7/2013	Gordon	2013/0332159	A1	12/2013	Federighi et al.
2013/0183944	A1	7/2013	Mozer et al.	2013/0332162	A1	12/2013	Keen
2013/0185059	A1	7/2013	Riccardi et al.	2013/0332164	A1	12/2013	Nalk
2013/0185074	A1	7/2013	Gruber et al.	2013/0332168	A1	12/2013	Kim et al.
2013/0185081	A1	7/2013	Cheyser et al.	2013/0332172	A1	12/2013	Prakash et al.
2013/0185336	A1	7/2013	Singh et al.	2013/0332400	A1	12/2013	González
2013/0187850	A1	7/2013	Schulz et al.	2013/0339256	A1	12/2013	Shroff
2013/0187857	A1	7/2013	Griffin et al.	2013/0343721	A1	12/2013	Abecassis
2013/0191117	A1	7/2013	Atti et al.	2013/0346068	A1	12/2013	Solem et al.
2013/0197911	A1	8/2013	Wei et al.	2013/0346347	A1	12/2013	Patterson et al.
2013/0198841	A1	8/2013	Poulson	2013/0347117	A1	12/2013	Parks et al.
2013/0204813	A1	8/2013	Master et al.	2014/0006012	A1	1/2014	Zhou et al.
2013/0204897	A1	8/2013	McDougall	2014/0006025	A1	1/2014	Krishnan et al.
2013/0207898	A1	8/2013	Sullivan et al.	2014/0006027	A1	1/2014	Kim et al.
2013/0218553	A1	8/2013	Fujii et al.	2014/0006030	A1	1/2014	Fleizach et al.
2013/0218560	A1	8/2013	Hsiao et al.	2014/0006153	A1	1/2014	Thangam et al.
2013/0219333	A1	8/2013	Palwe et al.	2014/0006483	A1	1/2014	Garmark et al.
2013/0222249	A1	8/2013	Pasquero et al.	2014/0006562	A1	1/2014	Handa et al.
2013/0225128	A1	8/2013	Gomar	2014/0006947	A1	1/2014	Garmark et al.
2013/0226935	A1	8/2013	Bai et al.	2014/0012574	A1	1/2014	Pasupalak et al.
2013/0231917	A1	9/2013	Naik	2014/0012580	A1	1/2014	Ganong et al.
2013/0234947	A1	9/2013	Kristensson et al.	2014/0012586	A1	1/2014	Rubin et al.
2013/0235987	A1	9/2013	Arroniz-Escobar et al.	2014/0012587	A1	1/2014	Park
2013/0238326	A1	9/2013	Kim et al.	2014/0019116	A1	1/2014	Lundberg et al.
2013/0238647	A1	9/2013	Thompson	2014/0019133	A1	1/2014	Bao et al.
2013/0244615	A1	9/2013	Miller et al.	2014/0019460	A1	1/2014	Sambrani et al.
2013/0246048	A1	9/2013	Nagase et al.	2014/0028735	A1	1/2014	Williams et al.
2013/0246050	A1	9/2013	Yu et al.	2014/0032453	A1	1/2014	Eustice et al.
2013/0246329	A1	9/2013	Pasquero et al.	2014/0033071	A1	1/2014	Gruber et al.
2013/0253911	A1	9/2013	Petri et al.	2014/0035823	A1	2/2014	Khoe et al.
2013/0253912	A1	9/2013	Medlock et al.	2014/0039888	A1	2/2014	Taubman et al.
2013/0268263	A1	10/2013	Park et al.	2014/0039893	A1	2/2014	Weiner
2013/0275117	A1	10/2013	Winer	2014/0039894	A1	2/2014	Shostak
2013/0275138	A1	10/2013	Gruber et al.	2014/0040274	A1	2/2014	Aravamudan et al.
2013/0275164	A1	10/2013	Gruber et al.	2014/0040748	A1	2/2014	Lemay et al.
2013/0275199	A1	10/2013	Proctor, Jr. et al.	2014/0040801	A1	2/2014	Patel et al.
2013/0275625	A1	10/2013	Taiivalsaari et al.	2014/0040918	A1	2/2014	Li et al.
2013/0275875	A1	10/2013	Gruber et al.	2014/0040961	A1	2/2014	Green, Sr. et al.
2013/0275899	A1	10/2013	Schubert et al.	2014/0046934	A1	2/2014	Zhou et al.
2013/0282709	A1	10/2013	Zhu et al.	2014/0047001	A1	2/2014	Phillips et al.
2013/0283168	A1	10/2013	Brown et al.	2014/0052451	A1	2/2014	Cheong et al.
2013/0285913	A1	10/2013	Griffin et al.	2014/0052680	A1	2/2014	Nitz et al.
2013/0289991	A1	10/2013	Eshwar et al.	2014/0052791	A1	2/2014	Chakra et al.
2013/0289993	A1	10/2013	Rao et al.	2014/0053082	A1	2/2014	Park et al.
2013/0289994	A1	10/2013	Newman et al.	2014/0053210	A1	2/2014	Cheong et al.
2013/0291015	A1	10/2013	Pan	2014/0057610	A1	2/2014	Olinicy et al.
2013/0297317	A1	11/2013	Lee et al.	2014/0059030	A1	2/2014	Hakkani-Tur et al.
2013/0297319	A1	11/2013	Kim	2014/0067361	A1	3/2014	Nikoulina et al.
2013/0297348	A1	11/2013	Cardoza et al.	2014/0067371	A1	3/2014	Liensberger
2013/0300645	A1	11/2013	Fedorov	2014/0067402	A1	3/2014	Kim
2013/0300648	A1	11/2013	Kim et al.	2014/0068751	A1	3/2014	Last et al.
2013/0303106	A1	11/2013	Martin	2014/0074454	A1	3/2014	Brown et al.
2013/0304479	A1	11/2013	Teller et al.	2014/0074466	A1	3/2014	Sharifi et al.
2013/0304758	A1	11/2013	Gruber et al.	2014/0074470	A1	3/2014	Jansche et al.
2013/0304815	A1	11/2013	Puente et al.	2014/0074472	A1	3/2014	Lin et al.
2013/0305119	A1	11/2013	Kern et al.	2014/0074483	A1	3/2014	Van Os
2013/0307855	A1	11/2013	Lamb et al.	2014/0074815	A1	3/2014	Plimton
2013/0307997	A1	11/2013	O'Keefe et al.	2014/0078065	A1	3/2014	Akkok et al.
2013/0308922	A1	11/2013	Sano et al.	2014/0079195	A1	3/2014	Srivastava et al.
				2014/0080428	A1	3/2014	Rhoads et al.
				2014/0081619	A1	3/2014	Solntseva et al.
				2014/0081633	A1	3/2014	Badaskar et al.
				2014/0082501	A1	3/2014	Bae et al.

(56)	References Cited						
	U.S. PATENT DOCUMENTS						
2014/0086458	A1	3/2014	Rogers et al.	2014/0214537	A1	7/2014	Yoo et al.
2014/0087711	A1	3/2014	Geyer et al.	2014/0215513	A1	7/2014	Ramer et al.
2014/0088961	A1	3/2014	Woodward et al.	2014/0218372	A1	8/2014	Missig et al.
2014/0095171	A1	4/2014	Lynch et al.	2014/0222436	A1	8/2014	Binder et al.
2014/0095172	A1	4/2014	Cabaco et al.	2014/0222678	A1	8/2014	Sheets et al.
2014/0095173	A1	4/2014	Lynch et al.	2014/0223377	A1	8/2014	Shaw et al.
2014/0095601	A1	4/2014	Abuelsaad et al.	2014/0223481	A1	8/2014	Fundament
2014/0096209	A1	4/2014	Saraf et al.	2014/0226503	A1	8/2014	Cooper et al.
2014/0098247	A1	4/2014	Rao et al.	2014/0229184	A1	8/2014	Shires
2014/0100847	A1	4/2014	Ishii et al.	2014/0230055	A1	8/2014	Boehl
2014/0108017	A1	4/2014	Mason et al.	2014/0232656	A1	8/2014	Pasquero et al.
2014/0114554	A1	4/2014	Lagassey	2014/0236595	A1	8/2014	Gray
2014/0115062	A1	4/2014	Liu et al.	2014/0236986	A1	8/2014	Guzman
2014/0115114	A1	4/2014	Garmark et al.	2014/0237042	A1	8/2014	Ahmed et al.
2014/0118155	A1	5/2014	Bowers et al.	2014/0244248	A1	8/2014	Arisoy et al.
2014/0122059	A1	5/2014	Patel et al.	2014/0244249	A1	8/2014	Mohamed et al.
2014/0122086	A1	5/2014	Kapur et al.	2014/0244254	A1	8/2014	Ju et al.
2014/0122136	A1	5/2014	Jayanthi	2014/0244257	A1	8/2014	Colibro et al.
2014/0122153	A1	5/2014	Truitt	2014/0244258	A1	8/2014	Song et al.
2014/0132935	A1	5/2014	Kim et al.	2014/0244263	A1	8/2014	Pontual et al.
2014/0134983	A1	5/2014	Jung et al.	2014/0244266	A1	8/2014	Brown et al.
2014/0135036	A1	5/2014	Bonanni et al.	2014/0244268	A1	8/2014	Abdelsamie et al.
2014/0136013	A1	5/2014	Wolverton et al.	2014/0244271	A1	8/2014	Lindahl
2014/0136187	A1	5/2014	Wolverton et al.	2014/0244712	A1	8/2014	Walters et al.
2014/0136195	A1	5/2014	Abdossalami et al.	2014/0245140	A1	8/2014	Brown et al.
2014/0136212	A1	5/2014	Kwon et al.	2014/0247383	A1	9/2014	Dave et al.
2014/0136946	A1	5/2014	Matas	2014/0247926	A1	9/2014	Gainsboro et al.
2014/0136987	A1	5/2014	Rodriguez	2014/0249817	A1	9/2014	Hart et al.
2014/0142922	A1	5/2014	Liang et al.	2014/0249821	A1	9/2014	Kennewick et al.
2014/0142923	A1	5/2014	Jones et al.	2014/0250046	A1	9/2014	Winn et al.
2014/0142935	A1	5/2014	Lindahl et al.	2014/0257809	A1	9/2014	Goel et al.
2014/0143550	A1	5/2014	Ganong, III et al.	2014/0257815	A1	9/2014	Zhao et al.
2014/0143721	A1	5/2014	Suzuki et al.	2014/0257902	A1	9/2014	Moore et al.
2014/0146200	A1	5/2014	Scott et al.	2014/0258857	A1	9/2014	Dykstra-Erickson et al.
2014/0152577	A1	6/2014	Yuen et al.	2014/0267022	A1	9/2014	Kim
2014/0153709	A1	6/2014	Byrd et al.	2014/0267599	A1	9/2014	Drouin et al.
2014/0155031	A1	6/2014	Lee et al.	2014/0272821	A1	9/2014	Pitschel et al.
2014/0156262	A1	6/2014	Yuen et al.	2014/0274005	A1	9/2014	Luna et al.
2014/0156279	A1	6/2014	Okamoto et al.	2014/0274203	A1	9/2014	Ganong et al.
2014/0157422	A1	6/2014	Livshits et al.	2014/0274211	A1	9/2014	Sejnoha et al.
2014/0163951	A1	6/2014	Nikoulina et al.	2014/0278343	A1	9/2014	Tran
2014/0163953	A1	6/2014	Parikh	2014/0278349	A1	9/2014	Grieves et al.
2014/0163954	A1	6/2014	Joshi et al.	2014/0278379	A1	9/2014	Coccaro et al.
2014/0163962	A1	6/2014	Castelli et al.	2014/0278390	A1	9/2014	Kingsbury et al.
2014/0163976	A1	6/2014	Park et al.	2014/0278391	A1	9/2014	Braho et al.
2014/0163977	A1	6/2014	Hoffmeister et al.	2014/0278394	A1	9/2014	Bastyr et al.
2014/0163981	A1	6/2014	Cook et al.	2014/0278406	A1	9/2014	Tsumura et al.
2014/0163995	A1	6/2014	Burns et al.	2014/0278413	A1	9/2014	Pitschel et al.
2014/0164305	A1	6/2014	Lynch et al.	2014/0278429	A1	9/2014	Ganong, III
2014/0164476	A1	6/2014	Thomson	2014/0278435	A1	9/2014	Ganong et al.
2014/0164532	A1	6/2014	Lynch et al.	2014/0278436	A1	9/2014	Khanna et al.
2014/0164533	A1	6/2014	Lynch et al.	2014/0278443	A1	9/2014	Gunn et al.
2014/0169795	A1	6/2014	Clough	2014/0278513	A1	9/2014	Prakash et al.
2014/0172878	A1	6/2014	Clark et al.	2014/0279739	A1	9/2014	Elkington et al.
2014/0173460	A1	6/2014	Kim	2014/0280107	A1	9/2014	Heymans et al.
2014/0180499	A1	6/2014	Cooper et al.	2014/0280138	A1	9/2014	Li et al.
2014/0180689	A1	6/2014	Kim et al.	2014/0280292	A1	9/2014	Skinder
2014/0180697	A1	6/2014	Torok et al.	2014/0280353	A1	9/2014	Delaney et al.
2014/0181865	A1	6/2014	Koganei	2014/0280450	A1	9/2014	Luna
2014/0188477	A1	7/2014	Zhang	2014/0281983	A1	9/2014	Xian et al.
2014/0195226	A1	7/2014	Yun et al.	2014/0282003	A1	9/2014	Gruber et al.
2014/0195230	A1	7/2014	Han et al.	2014/0282007	A1	9/2014	Fleizach
2014/0195233	A1	7/2014	Bapat	2014/0282045	A1	9/2014	Ayanam et al.
2014/0195244	A1	7/2014	Cha et al.	2014/0282201	A1	9/2014	Pasquero et al.
2014/0195251	A1	7/2014	Zeinstra et al.	2014/0282203	A1	9/2014	Pasquero et al.
2014/0195252	A1	7/2014	Gruber et al.	2014/0282586	A1	9/2014	Shear et al.
2014/0198048	A1	7/2014	Unruh et al.	2014/0282743	A1	9/2014	Howard et al.
2014/0203939	A1	7/2014	Harrington et al.	2014/0288990	A1	9/2014	Moore et al.
2014/0205076	A1	7/2014	Kumar et al.	2014/0289508	A1	9/2014	Wang
2014/0207439	A1	7/2014	Venkatapathy et al.	2014/0297267	A1	10/2014	Spencer et al.
2014/0207446	A1	7/2014	Klein et al.	2014/0297281	A1	10/2014	Togawa et al.
2014/0207466	A1	7/2014	Smadi et al.	2014/0297284	A1	10/2014	Gruber et al.
2014/0207468	A1	7/2014	Bartnik	2014/0297288	A1	10/2014	Yu et al.
2014/0207582	A1	7/2014	Flinn et al.	2014/0304605	A1	10/2014	Ohmura et al.
2014/0214429	A1	7/2014	Pantel	2014/0309996	A1	10/2014	Zhang
				2014/0310001	A1	10/2014	Kalns et al.
				2014/0310002	A1	10/2014	Nitz et al.
				2014/0310348	A1	10/2014	Keskitalo et al.
				2014/0316585	A1	10/2014	Boesveld et al.

(56)

References Cited

U.S. PATENT DOCUMENTS

2014/0317030	A1	10/2014	Shen et al.	2015/0067485	A1	3/2015	Kim et al.
2014/0317502	A1	10/2014	Brown et al.	2015/0067822	A1	3/2015	Randall
2014/0324884	A1	10/2014	Lindahl et al.	2015/0071121	A1	3/2015	Patil et al.
2014/0330569	A1	11/2014	Kolavennu et al.	2015/0073788	A1	3/2015	Allauzen et al.
2014/0337048	A1	11/2014	Brown et al.	2015/0073804	A1	3/2015	Senior et al.
2014/0337266	A1	11/2014	Wolverton et al.	2015/0074524	A1	3/2015	Nicholson et al.
2014/0337371	A1	11/2014	Li	2015/0074615	A1	3/2015	Han et al.
2014/0337438	A1	11/2014	Govande et al.	2015/0082229	A1	3/2015	Ouyang et al.
2014/0337751	A1	11/2014	Lim et al.	2015/0088511	A1	3/2015	Bharadwaj et al.
2014/0337814	A1	11/2014	Kalns et al.	2015/0088514	A1	3/2015	Typrin
2014/0342762	A1	11/2014	Hajdu et al.	2015/0088522	A1	3/2015	Hendrickson et al.
2014/0344627	A1	11/2014	Schaub et al.	2015/0088523	A1	3/2015	Schuster
2014/0344687	A1	11/2014	Durham et al.	2015/0095031	A1	4/2015	Conkie et al.
2014/0350924	A1	11/2014	Zurek et al.	2015/0095278	A1	4/2015	Flinn et al.
2014/0350933	A1	11/2014	Bak et al.	2015/0100313	A1	4/2015	Sharma
2014/0351741	A1	11/2014	Medlock et al.	2015/0100316	A1	4/2015	Williams et al.
2014/0351760	A1	11/2014	Skory et al.	2015/0100537	A1	4/2015	Grieves et al.
2014/0358519	A1	12/2014	Mirkin et al.	2015/0100983	A1	4/2015	Pan
2014/0358523	A1	12/2014	Sheth et al.	2015/0106093	A1	4/2015	Weeks et al.
2014/0361973	A1	12/2014	Raux et al.	2015/0113407	A1	4/2015	Hoffert et al.
2014/0363074	A1	12/2014	Dolfing et al.	2015/0120296	A1	4/2015	Stern et al.
2014/0364149	A1	12/2014	Marti et al.	2015/0120723	A1	4/2015	Deshmukh et al.
2014/0365209	A1	12/2014	Evermann	2015/0121216	A1	4/2015	Brown et al.
2014/0365214	A1	12/2014	Bayley	2015/0127337	A1	5/2015	Heigold et al.
2014/0365216	A1	12/2014	Gruber et al.	2015/0127348	A1	5/2015	Follis
2014/0365226	A1	12/2014	Sinha	2015/0127350	A1	5/2015	Agiomyrgiannakis
2014/0365227	A1	12/2014	Cash et al.	2015/0133109	A1	5/2015	Freeman et al.
2014/0365407	A1	12/2014	Brown et al.	2015/0134334	A1	5/2015	Sachidanandam et al.
2014/0365880	A1	12/2014	Bellegarda	2015/0135085	A1	5/2015	Shoham et al.
2014/0365885	A1	12/2014	Carson et al.	2015/0135123	A1	5/2015	Carr et al.
2014/0365895	A1	12/2014	Paulson et al.	2015/0142420	A1	5/2015	Sarikaya et al.
2014/0365922	A1	12/2014	Yang	2015/0142438	A1	5/2015	Dai et al.
2014/0365945	A1	12/2014	Karunamuni et al.	2015/0142447	A1	5/2015	Kennewick et al.
2014/0370817	A1	12/2014	Luna	2015/0142851	A1	5/2015	Gupta et al.
2014/0370841	A1	12/2014	Roberts et al.	2015/0143419	A1	5/2015	Bhagwat et al.
2014/0372112	A1	12/2014	Xue et al.	2015/0148013	A1	5/2015	Baldwin et al.
2014/0372356	A1	12/2014	Bilal et al.	2015/0149177	A1	5/2015	Kalns et al.
2014/0372931	A1	12/2014	Zhai et al.	2015/0149182	A1	5/2015	Kalns et al.
2014/0379334	A1	12/2014	Fry	2015/0149354	A1	5/2015	Mccoy
2014/0379341	A1	12/2014	Seo et al.	2015/0149469	A1	5/2015	Xu et al.
2014/0380285	A1	12/2014	Gabel et al.	2015/0154185	A1	6/2015	Waibel
2015/0003797	A1	1/2015	Schmidt	2015/0154976	A1	6/2015	Mutagi
2015/0006148	A1	1/2015	Goldszmit et al.	2015/0160855	A1	6/2015	Bi
2015/0006157	A1	1/2015	Andrade Silva et al.	2015/0161370	A1	6/2015	North et al.
2015/0006176	A1	1/2015	Pogue et al.	2015/0161521	A1	6/2015	Shah et al.
2015/0006178	A1	1/2015	Peng et al.	2015/0161989	A1	6/2015	Hsu et al.
2015/0006184	A1	1/2015	Marti et al.	2015/0162001	A1	6/2015	Kar et al.
2015/0006199	A1	1/2015	Snider et al.	2015/0163558	A1	6/2015	Wheatley
2015/0012271	A1	1/2015	Peng et al.	2015/0169284	A1	6/2015	Quast et al.
2015/0019219	A1	1/2015	Tzirkel-hancock et al.	2015/0169336	A1	6/2015	Harper et al.
2015/0019221	A1	1/2015	Lee et al.	2015/0170664	A1	6/2015	Doherty et al.
2015/0019974	A1	1/2015	Doi et al.	2015/0172262	A1	6/2015	Ortiz, Jr. et al.
2015/0031416	A1	1/2015	Wells et al.	2015/0172463	A1	6/2015	Quast et al.
2015/0033219	A1	1/2015	Breiner et al.	2015/0178388	A1	6/2015	Winnemoeller et al.
2015/0033275	A1	1/2015	Natani et al.	2015/0179176	A1	6/2015	Ryu et al.
2015/0039292	A1	2/2015	Suleman et al.	2015/0185964	A1	7/2015	Stout
2015/0039299	A1	2/2015	Weinstein et al.	2015/0186012	A1	7/2015	Coleman et al.
2015/0039305	A1	2/2015	Huang	2015/0186110	A1	7/2015	Kannan
2015/0039606	A1	2/2015	Salaka et al.	2015/0186154	A1	7/2015	Brown et al.
2015/0040012	A1	2/2015	Faaborg et al.	2015/0186155	A1	7/2015	Brown et al.
2015/0045003	A1	2/2015	Vora et al.	2015/0186156	A1	7/2015	Brown et al.
2015/0045007	A1	2/2015	Cash	2015/0186351	A1	7/2015	Hicks et al.
2015/0045068	A1	2/2015	Soffer et al.	2015/0187355	A1	7/2015	Parkinson et al.
2015/0046537	A1	2/2015	Rakib	2015/0187369	A1	7/2015	Dadu et al.
2015/0050633	A1	2/2015	Christmas et al.	2015/0189362	A1	7/2015	Lee et al.
2015/0053779	A1	2/2015	Adamek et al.	2015/0193379	A1	7/2015	Mehta
2015/0053781	A1	2/2015	Nelson et al.	2015/0193391	A1	7/2015	Khvostichenko et al.
2015/0058013	A1	2/2015	Pakhomov et al.	2015/0193392	A1	7/2015	Greenblatt et al.
2015/0058018	A1	2/2015	Georges et al.	2015/0194152	A1	7/2015	Katuri et al.
2015/0058785	A1	2/2015	Ookawara	2015/0195379	A1	7/2015	Zhang et al.
2015/0065200	A1	3/2015	Namgung et al.	2015/0195606	A1	7/2015	McDevitt
2015/0066494	A1	3/2015	Salvador et al.	2015/0199077	A1	7/2015	Zuger et al.
2015/0066496	A1	3/2015	Deoras et al.	2015/0199960	A1	7/2015	Huo et al.
2015/0066506	A1	3/2015	Romano et al.	2015/0199965	A1	7/2015	Leak et al.
2015/0066516	A1	3/2015	Nishikawa et al.	2015/0199967	A1	7/2015	Reddy et al.
				2015/0201064	A1	7/2015	Bells et al.
				2015/0201077	A1	7/2015	Konig et al.
				2015/0205858	A1	7/2015	Xie et al.
				2015/0208226	A1	7/2015	Kuusilinna et al.

(56)

References Cited

U.S. PATENT DOCUMENTS

2015/0212791	A1	7/2015	Kumar et al.	2015/0350031	A1	12/2015	Burks et al.
2015/0213796	A1	7/2015	Waltermann et al.	2015/0350342	A1	12/2015	Thorpe et al.
2015/0215258	A1	7/2015	Nowakowski et al.	2015/0352999	A1	12/2015	Bando et al.
2015/0220507	A1	8/2015	Mohajer et al.	2015/0355879	A1	12/2015	Beckhardt et al.
2015/0221304	A1	8/2015	Stewart	2015/0356410	A1	12/2015	Faith et al.
2015/0221307	A1	8/2015	Shah et al.	2015/0363587	A1	12/2015	Ahn et al.
2015/0227505	A1	8/2015	Morimoto	2015/0364128	A1	12/2015	Zhao et al.
2015/0227633	A1	8/2015	Shapira	2015/0364140	A1	12/2015	Thorn
2015/0228274	A1	8/2015	Leppnen et al.	2015/0370531	A1	12/2015	Faaborg
2015/0228281	A1	8/2015	Raniere	2015/0370780	A1	12/2015	Wang et al.
2015/0230095	A1	8/2015	Smith et al.	2015/0371215	A1	12/2015	Zhou et al.
2015/0234636	A1	8/2015	Barnes, Jr.	2015/0371529	A1	12/2015	Dolecki
2015/0234800	A1	8/2015	Patrick et al.	2015/0371639	A1	12/2015	Foerster et al.
2015/0242091	A1	8/2015	Lu et al.	2015/0371663	A1	12/2015	Gustafson et al.
2015/0243278	A1	8/2015	Kibre et al.	2015/0371665	A1	12/2015	Naik et al.
2015/0243283	A1	8/2015	Halash et al.	2015/0373183	A1	12/2015	Woolsey et al.
2015/0245154	A1	8/2015	Dadu et al.	2015/0379414	A1	12/2015	Yeh et al.
2015/0248651	A1	9/2015	Akutagawa et al.	2015/0379993	A1	12/2015	Subhojit et al.
2015/0248886	A1	9/2015	Sarikaya et al.	2015/0382047	A1	12/2015	Napolitano et al.
2015/0254057	A1	9/2015	Klein et al.	2015/0382079	A1	12/2015	Lister et al.
2015/0254058	A1	9/2015	Klein et al.	2015/0382147	A1	12/2015	Clark et al.
2015/0254333	A1	9/2015	Fife et al.	2016/0004690	A1	1/2016	Bangalore et al.
2015/0255071	A1	9/2015	Chiba	2016/0005320	A1	1/2016	deCharms et al.
2015/0256873	A1	9/2015	Klein et al.	2016/0012038	A1	1/2016	Edwards et al.
2015/0261496	A1	9/2015	Faaborg et al.	2016/0014476	A1	1/2016	Caliendo, Jr. et al.
2015/0261850	A1	9/2015	Mittal	2016/0018900	A1	1/2016	Tu et al.
2015/0269139	A1	9/2015	McAteer et al.	2016/0019886	A1	1/2016	Hong
2015/0277574	A1	10/2015	Jain et al.	2016/0026258	A1	1/2016	Ou et al.
2015/0278348	A1	10/2015	Paruchuri et al.	2016/0027431	A1	1/2016	Kurzweil et al.
2015/0278370	A1	10/2015	Stratvert et al.	2016/0028666	A1	1/2016	Li
2015/0279358	A1	10/2015	Kingsbury et al.	2016/0029316	A1	1/2016	Mohan et al.
2015/0279360	A1	10/2015	Mengibar et al.	2016/0034042	A1	2/2016	Joo
2015/0281380	A1	10/2015	Wang et al.	2016/0034811	A1	2/2016	Paulik et al.
2015/0286627	A1	10/2015	Chang et al.	2016/0042735	A1	2/2016	Vibbert et al.
2015/0286716	A1	10/2015	Snibbe et al.	2016/0042748	A1	2/2016	Jain et al.
2015/0287401	A1	10/2015	Lee et al.	2016/0048666	A1	2/2016	Dey et al.
2015/0287409	A1	10/2015	Jang	2016/0055422	A1	2/2016	Li
2015/0288629	A1	10/2015	Choi et al.	2016/0062605	A1	3/2016	Agarwal et al.
2015/0294086	A1	10/2015	Kare et al.	2016/0063998	A1	3/2016	Krishnamoorthy et al.
2015/0294377	A1	10/2015	Chow	2016/0070581	A1	3/2016	Soon-Shiong
2015/0294516	A1	10/2015	Chiang	2016/0071516	A1	3/2016	Lee et al.
2015/0295915	A1	10/2015	Xiu	2016/0071521	A1	3/2016	Haughey
2015/0302855	A1	10/2015	Kim et al.	2016/0072940	A1	3/2016	Cronin
2015/0302856	A1	10/2015	Kim et al.	2016/0077794	A1	3/2016	Kim et al.
2015/0302857	A1	10/2015	Yamada	2016/0078860	A1	3/2016	Paulik et al.
2015/0309997	A1	10/2015	Lee et al.	2016/0080165	A1	3/2016	Ehsani et al.
2015/0310858	A1	10/2015	Li et al.	2016/0086116	A1	3/2016	Rao et al.
2015/0310862	A1	10/2015	Dauphin et al.	2016/0091967	A1	3/2016	Prokofieva et al.
2015/0310879	A1	10/2015	Buchanan et al.	2016/0092447	A1	3/2016	Venkataraman et al.
2015/0312182	A1	10/2015	Langholz	2016/0092766	A1	3/2016	Sainath et al.
2015/0317069	A1	11/2015	Clements et al.	2016/0093291	A1	3/2016	Kim
2015/0317310	A1	11/2015	Eiche et al.	2016/0093298	A1	3/2016	Naik et al.
2015/0324041	A1	11/2015	Varley et al.	2016/0093301	A1	3/2016	Bellegarda et al.
2015/0324334	A1	11/2015	Lee et al.	2016/0093304	A1	3/2016	Kim et al.
2015/0331664	A1	11/2015	Osawa et al.	2016/0094700	A1	3/2016	Lee et al.
2015/0331711	A1	11/2015	Huang et al.	2016/0094979	A1	3/2016	Naik et al.
2015/0332667	A1	11/2015	Mason	2016/0098991	A1	4/2016	Luo et al.
2015/0339049	A1	11/2015	Kasemset et al.	2016/0104486	A1	4/2016	Penilla et al.
2015/0339391	A1	11/2015	Kang et al.	2016/0111091	A1	4/2016	Bakish
2015/0340033	A1	11/2015	Di Fabbri et al.	2016/0117386	A1	4/2016	Ajmera et al.
2015/0340040	A1	11/2015	Mun et al.	2016/0118048	A1	4/2016	Heide
2015/0340042	A1	11/2015	Sejnoha et al.	2016/0119338	A1	4/2016	Cheyer
2015/0341717	A1	11/2015	Song et al.	2016/0125048	A1	5/2016	Hamada
2015/0347086	A1	12/2015	Liedholm et al.	2016/0125071	A1	5/2016	Gabbai
2015/0347381	A1	12/2015	Bellegarda	2016/0132046	A1	5/2016	Beoughter et al.
2015/0347382	A1	12/2015	Dolfing et al.	2016/0132484	A1	5/2016	Nauze et al.
2015/0347385	A1	12/2015	Flor et al.	2016/0132488	A1	5/2016	Clark et al.
2015/0347393	A1	12/2015	Futrell et al.	2016/0133254	A1	5/2016	Vogel et al.
2015/0347733	A1	12/2015	Tsou et al.	2016/0139662	A1	5/2016	Dabhade
2015/0347985	A1	12/2015	Gross et al.	2016/0140951	A1	5/2016	Agiomyrgiannakis et al.
2015/0348547	A1	12/2015	Paulik et al.	2016/0140962	A1	5/2016	Sharifi
2015/0348548	A1	12/2015	Piernot et al.	2016/0147725	A1	5/2016	Patten et al.
2015/0348549	A1	12/2015	Giuli et al.	2016/0148610	A1	5/2016	Kennewick, Jr. et al.
2015/0348551	A1	12/2015	Gruber et al.	2016/0154880	A1	6/2016	Hoarty
2015/0348554	A1	12/2015	Orr et al.	2016/0155442	A1	6/2016	Kannan et al.
				2016/0155443	A1	6/2016	Khan et al.
				2016/0162456	A1	6/2016	Munro et al.
				2016/0163311	A1	6/2016	Crook et al.
				2016/0163312	A1	6/2016	Naik et al.

(56)		References Cited					
		U.S. PATENT DOCUMENTS					
2016/0170966	A1	6/2016	Kolo	2016/0359771	A1	12/2016	Sridhar
2016/0173578	A1	6/2016	Sharma et al.	2016/0360039	A1	12/2016	Sanghavi et al.
2016/0173617	A1	6/2016	Allinson	2016/0360336	A1	12/2016	Gross et al.
2016/0173960	A1	6/2016	Snibbe et al.	2016/0360382	A1	12/2016	Gross et al.
2016/0179462	A1	6/2016	Bjorkengren	2016/0364378	A1	12/2016	Futrell et al.
2016/0179787	A1	6/2016	Deleeuw	2016/0365101	A1	12/2016	Foy et al.
2016/0180844	A1	6/2016	Vanblon et al.	2016/0371250	A1	12/2016	Rhodes
2016/0182410	A1	6/2016	Janakiraman et al.	2016/0372112	A1	12/2016	Miller et al.
2016/0182709	A1	6/2016	Kim et al.	2016/0378747	A1	12/2016	Orr et al.
2016/0188181	A1	6/2016	Smith	2016/0379091	A1	12/2016	Lin et al.
2016/0188738	A1	6/2016	Gruber et al.	2016/0379626	A1	12/2016	Deisher et al.
2016/0189717	A1	6/2016	Kannan et al.	2016/0379633	A1	12/2016	Lehman et al.
2016/0198319	A1	7/2016	Huang et al.	2016/0379641	A1	12/2016	Liu et al.
2016/0210551	A1	7/2016	Lee et al.	2017/0003931	A1	1/2017	Dvortsov et al.
2016/0210981	A1	7/2016	Lee	2017/0004824	A1	1/2017	Yoo et al.
2016/0212488	A1	7/2016	Os et al.	2017/0011091	A1	1/2017	Chehrehghani
2016/0217784	A1	7/2016	Gelfenbeyn et al.	2017/0011303	A1	1/2017	Annareddy et al.
2016/0224540	A1	8/2016	Stewart et al.	2017/0011742	A1	1/2017	Jing et al.
2016/0224774	A1	8/2016	Pender	2017/0013124	A1	1/2017	Havelka et al.
2016/0225372	A1	8/2016	Cheung et al.	2017/0018271	A1	1/2017	Khan et al.
2016/0239645	A1	8/2016	Heo et al.	2017/0019987	A1	1/2017	Dragone et al.
2016/0240187	A1	8/2016	Fleizach et al.	2017/0025124	A1	1/2017	Mixter et al.
2016/0240189	A1	8/2016	Lee et al.	2017/0031576	A1	2/2017	Saoji et al.
2016/0247061	A1	8/2016	Trask et al.	2017/0032783	A1	2/2017	Lord et al.
2016/0253312	A1	9/2016	Rhodes	2017/0032791	A1	2/2017	Elson et al.
2016/0253528	A1	9/2016	Gao et al.	2017/0039475	A1	2/2017	Cheyser et al.
2016/0259623	A1	9/2016	Sumner et al.	2017/0040002	A1	2/2017	Basson et al.
2016/0259656	A1	9/2016	Sumner et al.	2017/0055895	A1	3/2017	Des Jardins et al.
2016/0259779	A1	9/2016	Labsk et al.	2017/0060853	A1	3/2017	Lee et al.
2016/0260431	A1	9/2016	Newendorp et al.	2017/0061423	A1	3/2017	Bryant et al.
2016/0260433	A1	9/2016	Sumner et al.	2017/0068423	A1	3/2017	Napolitano et al.
2016/0260434	A1	9/2016	Gelfenbeyn et al.	2017/0068513	A1	3/2017	Stasior et al.
2016/0260436	A1	9/2016	Lemay et al.	2017/0068550	A1	3/2017	Zeitlin
2016/0266871	A1	9/2016	Schmid et al.	2017/0068670	A1	3/2017	Orr et al.
2016/0267904	A1	9/2016	Biadys et al.	2017/0076720	A1	3/2017	Gopalan et al.
2016/0275941	A1	9/2016	Bellegarda et al.	2017/0076721	A1	3/2017	Bargetzi et al.
2016/0275947	A1	9/2016	Li et al.	2017/0083179	A1	3/2017	Gruber et al.
2016/0282824	A1	9/2016	Smallwood et al.	2017/0083285	A1	3/2017	Meyers et al.
2016/0282956	A1	9/2016	Ouyang et al.	2017/0083504	A1	3/2017	Huang
2016/0284005	A1	9/2016	Daniel et al.	2017/0085547	A1	3/2017	De Aguiar et al.
2016/0284199	A1	9/2016	Dotan-Cohen et al.	2017/0090569	A1	3/2017	Levesque
2016/0286045	A1	9/2016	Shaltiel et al.	2017/0091168	A1	3/2017	Bellegarda et al.
2016/0293168	A1	10/2016	Chen	2017/0092270	A1	3/2017	Newendorp et al.
2016/0299685	A1	10/2016	Zhai et al.	2017/0092278	A1	3/2017	Evermann et al.
2016/0299882	A1	10/2016	Hegerty et al.	2017/0102837	A1	4/2017	Toumpelis
2016/0299883	A1	10/2016	Zhu et al.	2017/0102915	A1	4/2017	Kuscher et al.
2016/0307566	A1	10/2016	Bellegarda	2017/0103749	A1	4/2017	Zhao et al.
2016/0313906	A1	10/2016	Kilchenko et al.	2017/0105190	A1	4/2017	Logan et al.
2016/0314788	A1	10/2016	Jitkoff et al.	2017/0116177	A1	4/2017	Walia
2016/0314792	A1	10/2016	Alvarez et al.	2017/0116989	A1	4/2017	Yadgar et al.
2016/0315996	A1	10/2016	Ha et al.	2017/0124190	A1	5/2017	Wang et al.
2016/0317924	A1	11/2016	Tanaka et al.	2017/0125016	A1	5/2017	Wang
2016/0321261	A1	11/2016	Spasojevic et al.	2017/0127124	A9	5/2017	Wilson et al.
2016/0322045	A1	11/2016	Hatfeild et al.	2017/0131778	A1	5/2017	Iyer
2016/0322048	A1	11/2016	Amano et al.	2017/0132019	A1	5/2017	Karashchuk et al.
2016/0322050	A1	11/2016	Wang et al.	2017/0132199	A1	5/2017	Vescovi et al.
2016/0328205	A1	11/2016	Agrawal et al.	2017/0140644	A1	5/2017	Hwang et al.
2016/0328893	A1	11/2016	Cordova et al.	2017/0148044	A1	5/2017	Fukuda et al.
2016/0336007	A1	11/2016	Hanazawa	2017/0154033	A1	6/2017	Lee
2016/0336010	A1	11/2016	Lindahl	2017/0154055	A1	6/2017	Dimson et al.
2016/0336024	A1	11/2016	Choi et al.	2017/0155940	A1	6/2017	Ji et al.
2016/0337299	A1	11/2016	Lane et al.	2017/0161018	A1	6/2017	Lemay et al.
2016/0337301	A1	11/2016	Rollins et al.	2017/0161268	A1	6/2017	Badaskar
2016/0342685	A1	11/2016	Basu et al.	2017/0161293	A1	6/2017	Ionescu et al.
2016/0342781	A1	11/2016	Jeon	2017/0169818	A1	6/2017	VanBlon et al.
2016/0351190	A1	12/2016	Binder et al.	2017/0169819	A1	6/2017	Mese et al.
2016/0352567	A1	12/2016	Robbins et al.	2017/0177547	A1	6/2017	Ciereszko et al.
2016/0357304	A1	12/2016	Hatori et al.	2017/0178619	A1	6/2017	Naik et al.
2016/0357728	A1	12/2016	Bellegarda et al.	2017/0178626	A1	6/2017	Gruber et al.
2016/0357790	A1	12/2016	Elkington et al.	2017/0180499	A1	6/2017	Gelfenbeyn et al.
2016/0357861	A1	12/2016	Carlhian et al.	2017/0185375	A1	6/2017	Martel et al.
2016/0357870	A1	12/2016	Hentschel et al.	2017/0185581	A1	6/2017	Bojja et al.
2016/0358598	A1	12/2016	Williams et al.	2017/0186429	A1	6/2017	Giuli et al.
2016/0358600	A1	12/2016	Nallasamy et al.	2017/0193083	A1	7/2017	Bhatt et al.
2016/0358619	A1	12/2016	Ramprasad et al.	2017/0195493	A1	7/2017	Kasilya Sudarsan et al.
				2017/0199870	A1	7/2017	Zheng et al.
				2017/0199874	A1	7/2017	Patel et al.
				2017/0200066	A1	7/2017	Wang et al.
				2017/0206899	A1	7/2017	Bryant et al.

(56)

References Cited

U.S. PATENT DOCUMENTS

2017/0221486	A1	8/2017	Kurata et al.
2017/0227935	A1	8/2017	Su et al.
2017/0228367	A1	8/2017	Pasupalak et al.
2017/0228382	A1	8/2017	Haviv et al.
2017/0230429	A1	8/2017	Garmark et al.
2017/0230709	A1	8/2017	Van Os et al.
2017/0236512	A1	8/2017	Williams et al.
2017/0242653	A1	8/2017	Lang et al.
2017/0242657	A1	8/2017	Jarvis et al.
2017/0243468	A1	8/2017	Dotan-Cohen et al.
2017/0256256	A1	9/2017	Wang et al.
2017/0263247	A1	9/2017	Kang et al.
2017/0263248	A1	9/2017	Gruber et al.
2017/0263249	A1	9/2017	Akbacak et al.
2017/0264451	A1	9/2017	Yu et al.
2017/0264711	A1	9/2017	Natarajan et al.
2017/0278514	A1	9/2017	Mathias et al.
2017/0285915	A1	10/2017	Napolitano et al.
2017/0286397	A1	10/2017	Gonzalez
2017/0295446	A1	10/2017	Thagadur Shivappa
2017/0311005	A1	10/2017	Lin
2017/0316775	A1	11/2017	Le et al.
2017/0316782	A1	11/2017	Haughay et al.
2017/0323637	A1	11/2017	Naik
2017/0329490	A1	11/2017	Esinovskaya et al.
2017/0329572	A1	11/2017	Shah et al.
2017/0345411	A1	11/2017	Raitio et al.
2017/0346949	A1	11/2017	Sanghavi et al.
2017/0352346	A1	12/2017	Paulik et al.
2017/0352350	A1	12/2017	Booker et al.
2017/0357478	A1	12/2017	Piersol et al.
2017/0357632	A1	12/2017	Pagallo et al.
2017/0357633	A1	12/2017	Wang et al.
2017/0357637	A1	12/2017	Nell et al.
2017/0357640	A1	12/2017	Bellegarda et al.
2017/0357716	A1	12/2017	Bellegarda et al.
2017/0358300	A1	12/2017	Laurens et al.
2017/0358301	A1	12/2017	Raitio et al.
2017/0358302	A1	12/2017	Orr et al.
2017/0358303	A1	12/2017	Walker, II et al.
2017/0358304	A1	12/2017	Castillo et al.
2017/0358305	A1	12/2017	Kudurshian et al.
2017/0371885	A1	12/2017	Aggarwal et al.
2017/0374093	A1	12/2017	Dhar et al.
2018/0007060	A1	1/2018	Leblang et al.
2018/0007538	A1	1/2018	Naik et al.
2018/0012596	A1	1/2018	Piernot et al.
2018/0018248	A1	1/2018	Bhargava et al.
2018/0033431	A1	2/2018	Newendorp et al.
2018/0047406	A1	2/2018	Park
2018/0054505	A1	2/2018	Hart et al.
2018/0060032	A1	3/2018	Boesen
2018/0060312	A1	3/2018	Won
2018/0061400	A1	3/2018	Carbune et al.
2018/0063624	A1	3/2018	Boesen
2018/0067914	A1	3/2018	Chen et al.
2018/0069743	A1	3/2018	Bakken et al.
2018/0090143	A1	3/2018	Saddler et al.
2018/0096683	A1	4/2018	James et al.
2018/0107945	A1	4/2018	Gao et al.
2018/0108346	A1	4/2018	Paulik et al.
2018/0122378	A1	5/2018	Mixter et al.
2018/0130470	A1	5/2018	Lemay et al.
2018/0130471	A1	5/2018	Trufinescu et al.
2018/0137856	A1	5/2018	Gilbert
2018/0137857	A1	5/2018	Zhou et al.
2018/0144748	A1	5/2018	Leong
2018/0157372	A1	6/2018	Kurabayashi
2018/0182376	A1	6/2018	Van Gysel et al.
2018/0190273	A1	7/2018	Karimli et al.
2018/0196683	A1	7/2018	Radebaugh et al.
2018/0213448	A1	7/2018	Segal et al.
2018/0218735	A1	8/2018	Hunt et al.
2018/0232203	A1	8/2018	Gelfenbeyn et al.
2018/0253652	A1	9/2018	Palzer et al.
2018/0270343	A1	9/2018	Rout et al.
2018/0276197	A1	9/2018	Nell et al.
2018/0278740	A1	9/2018	Choi et al.
2018/0308485	A1	10/2018	Kudurshian et al.
2018/0308486	A1	10/2018	Saddler et al.
2018/0322112	A1	11/2018	Bellegarda et al.
2018/0329677	A1	11/2018	Gruber et al.
2018/0329957	A1	11/2018	Frazzingaro et al.
2018/0329982	A1	11/2018	Patel et al.
2018/0330714	A1	11/2018	Paulik et al.
2018/0330721	A1	11/2018	Thomson et al.
2018/0330722	A1	11/2018	Newendorp et al.
2018/0330723	A1	11/2018	Acero et al.
2018/0330730	A1	11/2018	Garg et al.
2018/0330731	A1	11/2018	Zeitlin et al.
2018/0330733	A1	11/2018	Orr et al.
2018/0330737	A1	11/2018	Paulik et al.
2018/0332118	A1	11/2018	Phipps et al.
2018/0336184	A1	11/2018	Bellegarda et al.
2018/0336275	A1	11/2018	Graham et al.
2018/0336449	A1	11/2018	Adan et al.
2018/0336892	A1	11/2018	Kim et al.
2018/0336894	A1	11/2018	Graham et al.
2018/0336905	A1	11/2018	Kim et al.
2018/0350345	A1	12/2018	Naik
2018/0373487	A1	12/2018	Gruber et al.
2018/0374484	A1	12/2018	Huang et al.
2019/0012141	A1	1/2019	Piersol et al.
2019/0012449	A1	1/2019	Cheyer
2019/0014450	A1	1/2019	Gruber et al.
2019/0034040	A1	1/2019	Shah et al.
2019/0051309	A1	2/2019	Kim et al.
2019/0095050	A1	3/2019	Gruber et al.
2019/0095171	A1	3/2019	Carson et al.

FOREIGN PATENT DOCUMENTS

CA	2694314	A1	8/2010
CA	2792412	A1	7/2011
CA	2666438	C	6/2013
CN	101416471	A	4/2009
CN	101427244	A	5/2009
CN	101448340	A	6/2009
CN	101453498	A	6/2009
CN	101499156	A	8/2009
CN	101500041	A	8/2009
CN	101515952	A	8/2009
CN	101535983	A	9/2009
CN	101547396	A	9/2009
CN	101557432	A	10/2009
CN	101601088	A	12/2009
CN	101604521	A	12/2009
CN	101632316	A	1/2010
CN	101636736	A	1/2010
CN	101673544	A	3/2010
CN	101751387	A	6/2010
CN	101833286	A	9/2010
CN	101847405	A	9/2010
CN	101894547	A	11/2010
CN	101930789	A	12/2010
CN	101939740	A	1/2011
CN	101951553	A	1/2011
CN	102056026	A	5/2011
CN	102137085	A	7/2011
CN	102137193	A	7/2011
CN	102160043	A	8/2011
CN	102201235	A	9/2011
CN	102214187	A	10/2011
CN	102237088	A	11/2011
CN	102246136	A	11/2011
CN	202035047	U	11/2011
CN	102282609	A	12/2011
CN	202092650	U	12/2011
CN	102368256	A	3/2012
CN	102405463	A	4/2012
CN	102498457	A	6/2012
CN	102629246	A	8/2012
CN	102682769	A	9/2012
CN	102682771	A	9/2012

(56) References Cited								
FOREIGN PATENT DOCUMENTS								
CN	102685295	A	9/2012	EP	2985984	A2	2/2016	
CN	102693725	A	9/2012	EP	3035329	A1	6/2016	
CN	202453859	U	9/2012	EP	3224708	A1	10/2017	
CN	102750087	A	10/2012	EP	3246916	A1	11/2017	
CN	102792320	A	11/2012	EP	3300074	A1	3/2018	
CN	102801853	A	11/2012	EP	2983065	B1	8/2018	
CN	102870065	A	1/2013	JP	2000207422	A *	7/2000 G06F 17/2785
CN	102917004	A	2/2013	JP	2009-2850	A	1/2009	
CN	102917271	A	2/2013	JP	2009-503623	A	1/2009	
CN	102918493	A	2/2013	JP	2009-36999	A	2/2009	
CN	103035240	A	4/2013	JP	2009-505142	A	2/2009	
CN	103038728	A	4/2013	JP	2009-47920	A	3/2009	
CN	103093334	A	5/2013	JP	2009-069062	A	4/2009	
CN	103135916	A	6/2013	JP	2009-98490	A	5/2009	
CN	103198831	A	7/2013	JP	2009-110300	A	5/2009	
CN	103209369	A	7/2013	JP	2009-116841	A	5/2009	
CN	103236260	A	8/2013	JP	2009-134409	A	6/2009	
CN	103292437	A	9/2013	JP	2009-140444	A	6/2009	
CN	103365279	A	10/2013	JP	2009-169470	A	7/2009	
CN	103562863	A	2/2014	JP	2009-177440	A	8/2009	
CN	103744761	A	4/2014	JP	2009-186989	A	8/2009	
CN	103760984	A	4/2014	JP	2009-193448	A	8/2009	
CN	103795850	A	5/2014	JP	2009-193457	A	8/2009	
CN	103930945	A	7/2014	JP	2009-193532	A	8/2009	
CN	104038621	A	9/2014	JP	2009-205367	A	9/2009	
CN	104090652	A	10/2014	JP	2009-223840	A	10/2009	
CN	104144377	A	11/2014	JP	2009-294913	A	12/2009	
CN	104281259	A	1/2015	JP	2009-294946	A	12/2009	
CN	104284257	A	1/2015	JP	2009-543166	A	12/2009	
CN	104335234	A	2/2015	JP	2010-66519	A	3/2010	
CN	104423625	A	3/2015	JP	2010-78979	A	4/2010	
CN	104463552	A	3/2015	JP	2010-108378	A	5/2010	
CN	104516522	A	4/2015	JP	2010-518475	A	5/2010	
CN	104854583	A	8/2015	JP	2010-518526	A	5/2010	
CN	104951077	A	9/2015	JP	2010-146347	A	7/2010	
CN	105100356	A	11/2015	JP	2010-157207	A	7/2010	
CN	105247511	A	1/2016	JP	2010-166478	A	7/2010	
CN	105264524	A	1/2016	JP	2010-205111	A	9/2010	
CN	105471705	A	4/2016	JP	2010-224236	A	10/2010	
CN	107919123	A	4/2018	JP	4563106	B2	10/2010	
DE	102008024258	A1	11/2009	JP	2010-535377	A	11/2010	
DE	202016008226	U1	5/2017	JP	2010-287063	A	12/2010	
EP	1909263	B1	1/2009	JP	2011-33874	A	2/2011	
EP	1335620	B1	3/2009	JP	2011-41026	A	2/2011	
EP	2069895	A1	6/2009	JP	2011-45005	A	3/2011	
EP	2081185	A1	7/2009	JP	2011-59659	A	3/2011	
EP	2094032	A1	8/2009	JP	2011-81541	A	4/2011	
EP	2096840	A1	9/2009	JP	2011-525045	A	9/2011	
EP	2107553	A1	10/2009	JP	2011-238022	A	11/2011	
EP	2109295	A1	10/2009	JP	2011-250027	A	12/2011	
EP	1720375	B1	7/2010	JP	2012-014394	A	1/2012	
EP	2205010	A1	7/2010	JP	2012-33997	A	2/2012	
EP	2309491	A1	4/2011	JP	2012-508530	A	4/2012	
EP	2329348	A0	6/2011	JP	2012-089020	A	5/2012	
EP	2339576	A2	6/2011	JP	2012-116442	A	6/2012	
EP	2355093	A2	8/2011	JP	2012-142744	A	7/2012	
EP	2400373	A1	12/2011	JP	2012-147063	A	8/2012	
EP	2431842	A2	3/2012	JP	2012-518847	A	8/2012	
EP	2523188	A1	11/2012	JP	2013-37688	A	2/2013	
EP	2551784	A1	1/2013	JP	2013-511214	A	3/2013	
EP	2555536	A1	2/2013	JP	2013-65284	A	4/2013	
EP	2575128	A2	4/2013	JP	2013-73240	A	4/2013	
EP	2632129	A1	8/2013	JP	2013-513315	A	4/2013	
EP	2669889	A2	12/2013	JP	2013-080476	A	5/2013	
EP	2683175	A1	1/2014	JP	2013-517566	A	5/2013	
EP	2733598	A2	5/2014	JP	2013-134430	A	7/2013	
EP	2760015	A1	7/2014	JP	2013-140520	A	7/2013	
EP	2801890	A1	11/2014	JP	2013-527947	A	7/2013	
EP	2801972	A1	11/2014	JP	2013-528012	A	7/2013	
EP	2824564	A1	1/2015	JP	2013-156349	A	8/2013	
EP	2849177	A1	3/2015	JP	2013-200423	A	10/2013	
EP	2930715	A1	10/2015	JP	2013-205999	A	10/2013	
EP	2938022	A1	10/2015	JP	2013-238936	A	11/2013	
EP	2940556	A1	11/2015	JP	2014-10688	A	1/2014	
EP	2950307	A1	12/2015	JP	2014-026629	A	2/2014	
				JP	2014-60600	A	4/2014	
				JP	2014-72586	A	4/2014	
				JP	2014-077969	A	5/2014	
				JP	2014/109889	A	6/2014	

(56) References Cited						
FOREIGN PATENT DOCUMENTS						
			TW	201245989	A1	11/2012
			TW	201312548	A1	3/2013
			WO	WO-2004097664	A2 *	11/2004
			WO	WO-2005022408	A1 *	3/2005
			WO	WO-2005098669	A1 *	10/2005
			WO	2009/009240	A2	1/2009
			WO	2009/016631	A2	2/2009
			WO	2009/017280	A1	2/2009
			WO	2009/034686	A1	3/2009
			WO	2009/075912	A1	6/2009
			WO	2009/104126	A1	8/2009
			WO	2009/156438	A1	12/2009
			WO	2009/156978	A1	12/2009
			WO	2010/013369	A1	2/2010
			WO	2010/054373	A2	5/2010
			WO	2010/075623	A1	7/2010
			WO	2010/100937	A1	9/2010
			WO	2010/141802	A1	12/2010
			WO	2010/144651	A2	12/2010
			WO	2011/057346	A1	5/2011
			WO	2011/060106	A1	5/2011
			WO	2011/088053	A2	7/2011
			WO	2011/093025	A1	8/2011
			WO	2011/116309	A1	9/2011
			WO	2011/133543	A1	10/2011
			WO	2011/150730	A1	12/2011
			WO	2011/163350	A1	12/2011
			WO	2011/088053	A3	1/2012
			WO	2012/019020	A1	2/2012
			WO	2012/019637	A1	2/2012
			WO	2012/129231	A1	9/2012
			WO	2012/135157	A2	10/2012
			WO	2012/154317	A1	11/2012
			WO	2012/155079	A2	11/2012
			WO	2012/167168	A2	12/2012
			WO	2013/009578	A2	1/2013
			WO	2013/022135	A1	2/2013
			WO	2013/022223	A2	2/2013
			WO	2013/048880	A1	4/2013
			WO	2013/049358	A1	4/2013
			WO	2013/163113	A1	10/2013
			WO	2013/169842	A2	11/2013
			WO	2013/173504	A1	11/2013
			WO	2013/173511	A2	11/2013
			WO	2013/176847	A1	11/2013
			WO	2013/184953	A1	12/2013
			WO	2013/184990	A1	12/2013
			WO	2014/003138	A1	1/2014
			WO	2014/021967	A1	2/2014
			WO	2014/022148	A1	2/2014
			WO	2014/028797	A1	2/2014
			WO	2014/031505	A1	2/2014
			WO	2014/047047	A1	3/2014
			WO	2014/066352	A1	5/2014
			WO	2014/070872	A2	5/2014
			WO	2014/078965	A1	5/2014
			WO	2014/096506	A1	6/2014
			WO	2014/124332	A2	8/2014
			WO	2014/137074	A1	9/2014
			WO	2014/138604	A1	9/2014
			WO	2014/143959	A2	9/2014
			WO	2014/144579	A1	9/2014
			WO	2014/159581	A1	10/2014
			WO	2014/197336	A1	12/2014
			WO	2014/200728	A1	12/2014
			WO	2014/204659	A2	12/2014
			WO	2015/018440	A1	2/2015
			WO	2015/029379	A1	3/2015
			WO	2015/030796	A1	3/2015
			WO	2015/041892	A1	3/2015
			WO	2015/084659	A1	6/2015
			WO	2015/092943	A1	6/2015
			WO	2015/094169	A1	6/2015
			WO	2015/094369	A1	6/2015
			WO	2015/099939	A1	7/2015
			WO	2015/116151	A1	8/2015
			WO	2015/151133	A1	10/2015
			WO	2015/153310	A1	10/2015
			WO	2015/157013	A1	10/2015

(56)

References Cited

FOREIGN PATENT DOCUMENTS

WO	2015/183401	A1	12/2015
WO	2015/183699	A1	12/2015
WO	2015/184186	A1	12/2015
WO	2015/200207	A1	12/2015
WO	2016/027933	A1	2/2016
WO	2016/028946	A1	2/2016
WO	2016/033257	A1	3/2016
WO	2016/054230	A1	4/2016
WO	2016/057268	A1	4/2016
WO	2016/075081	A1	5/2016
WO	2016/085775	A2	6/2016
WO	2016/100139	A1	6/2016
WO	2016/111881	A1	7/2016
WO	2016/144840	A1	9/2016
WO	2016/144982	A1	9/2016
WO	2016/175354	A1	11/2016
WO	2016/190950	A1	12/2016
WO	2016/209444	A1	12/2016
WO	2017/044260	A1	3/2017
WO	2017/044629	A1	3/2017
WO	2017/053311	A1	3/2017
WO	2017/160487	A1	9/2017

OTHER PUBLICATIONS

Luyuan Lin, An Assistive Handwashing System with Emotional Intelligence. (Year: 2014).*

Sean Luke, Ontology-Based Knowledge Discovery on the World-Wide Web. (Year: 1996).*

Natalya Fridman Noy, SMART: Automated Support for Ontology Merging and Alignment. (Year: 1999).*

Andreas Hotho, Ontology-based Text Document Clustering. (Year: 2002).*

Susan Gauch, Ontology-based personalized search and browsing. (Year: 2001).*

David E. Wilkins, Interactive Execution Monitoring of Agent Teams. (Year: 2003).*

"Galaxy S7: How to Adjust Screen Timeout & Lock Screen Timeout", Available online at: <youtube.com/watch?v=n6e1WKUS2ww>, Jun. 9, 2016, 1 page.

"Hey Google: How to Create a Shopping List with Your Google Assistant, Available online at: <https://www.youtube.com/watch?v=w9NCsElax1Y>, May 25, 2018, 1 page.

"How to Enable Google Assistant on Galaxy 57 and other Android Phones (No Root)", Available online at: <youtube.com/watch?v=HekiQbWyksE>, Mar. 20, 2017, 1 page.

"How to Use Ok Google Assistant Even Phone is Locked, Available online at: <youtube.com/watch?v=9B_gP4j_SP8>, Mar. 12, 2018, 1 page.

"Ask Alexa—Things That Are Smart Wiki", Available online at <URL: http://thingsthataresmart.wiki/index.php?title=Ask_Alexa&oldid=4283>, [retrieved from internet on Aug. 2, 2017], Jun. 8, 2016, pp. 1-31.

"Directv™ Voice", Now Part of the Directv Mobile App for Phones, Sep. 18, 2013, 5 pages.

"The world of Virtual Assistants—more SemTech . . .", End of Business as Usual—Glenn's External blog, Online Available at <https://web.archive.org/web/20091101840940/http://glennas.wordpress.com/2009/10/17/the-world-of-virtual-assistants-more-semtech/>, Oct. 17, 2009, 5 pages.

Asakura et al., "What LG thinks; How the TV should be in the Living Room", HiVi, vol. 31, No. 7 (Jul. 2013), Stereo Sound Publishing, Inc., Jun. 17, 2013, pp. 68-71 (Official Copy Only). (See Communication under 37 CFR § 1.98(a) (3)).

Ashbrook, Daniel L., "Enabling Mobile Microinteractions", Retrieved from the Internet: URL: <http://danielashbrook.com/wp-content/uploads/2012/06/2009-Ashbrook-Thesis.pdf>, May 2010, 186 pages.

Ashingtondtech & Gaming, "SwipeStatusBar—Reveal the Status Bar in a Fullscreen App", Online Available at: <https://www.youtube.com/watch?v=wA_tT9IAreQ>, Jul. 1, 2013, 3 pages.

Bellegarda, Jerome, "Spoken Language Understanding for Natural Interaction: The Siri Experience", Slideshow retrieved from: <https://www.uni-ulm.de/fileadmin/website_uni_ulm/iui.iwdsds2012/files/Bellegarda.pdf>, International Workshop on Spoken Dialog Systems (IWSDS) 2012, May 2012, pp. 1-43.

Cambria et al., "Jumping NLP Curves: A Review of Natural Language Processing Research", IEEE Computational Intelligence Magazine, 2014, vol. 9, May 2014, pp. 48-57.

Earthing1984, "Samsung Galaxy Smart Stay Feature Explained", Available online at: <youtube.com/watch?v=RpjbNtSjupl>, May 29, 2013, 1 page.

Filipowicz, Luke, "How to use the Quick Type Keyboard in iOS 8", available online at .imore.com/comment/568232>, Oct. 11, 2014, pp. 1-17.

Finkel et al., "Joint Parsing and Named Entity Recognition", Human Language Technologies: The 2009 Annual Conference of the North American Chapter of the ACL, Jun. 2009, pp. 326-334.

Google Developers, "Voice Search in Your App", Available online at: <youtube.com/watch?v=PS1FbB5qWEI>, Nov. 12, 2014, 1 page.

IClarified, "How to Use Voice Control On Your iPhone 3GS", Online Available at: .iclarified.com/4296/how-to-use-voice-control-on-your-iphone-3g-s>, Jun. 19, 2009, 16 pages.

INews and Tech, "How To Use The QuickType Keyboard In iOS 8", Available online at: <inewsandtech.com/how-to-use-the-quicktype-keyboard-in-ios-8/>, Sep. 17, 2014, 6 pages.

IOS 8 Release, "Quick Type Keyboard on iOS 8 Makes Typing Easier", Retrieved from the Internet: URL: <youtube.com/watch?v=0CidLR4fhVU>, [Retrieved on Nov. 23, 2018], XP054978896, Jun. 3, 2014, 1 page.

Jonsson et al., "Proximity-based Reminders Using Bluetooth", 2014 IEEE International Conference on Pervasive Computing and Communications Demonstrations, 2014, pp. 151-153.

Karn, Ujjwal, "An Intuitive Explanation of Convolutional Neural Networks", The Data Science Blog, Aug. 11, 2016, 23 pages.

Liou et al., "Autoencoder for Words", Neurocomputing, vol. 139, Sep. 2014, pp. 84-96.

Majerus, Wesley, "Cell Phone Accessibility for your Blind Child", Retrieved from the Internet <URL: https://web.archive.org/web/20100210001100/https://nfb.org/images/nfb/publications/fr/fr283/fr280314.htm>, 2010, pp. 1-5.

Marketing Land, "Amazon Echo: Play Music", Online Available at: <outube.com/watch?v=A7V5NPbsXi4>, Apr. 27, 2015, 3 pages.

Mhatre et al., "Donna Interactive Chat-bot acting as a Personal Assistant", International Journal of Computer Applications (0975-8887), vol. 140, No. 10, Apr. 2016, 6 pages.

Mikolov et al., "Linguistic Regularities in Continuous Space Word Representations", Proceedings of NAACL-HLT, Jun. 9-14, 2013, pp. 746-751.

Morrison, Jonathan, "iPhone 5 Siri Demo", Online Available at <youtube.com/watch?v=_wHWwG5lhWc>, Sep. 21, 2012, 3 pages.

Nakamura, Satoshi, "Overcoming the Language Barrier with Speech Translation Technology, Science & Technology Trends", Quarterly Review No. 31, Apr. 2009, pp. 36-49.

Nakazawa et al., "Detection and Labeling of Significant Scenes from TV program based on Twitter Analysis", Proceedings of the 3rd Forum on Data Engineering and Information Management (deim 2011 proceedings), IEICE Data Engineering Technical Group, Available online at: <http://db-event.jp.org/deim2011/proceedings/pdf/f5-6.pdf>, Feb. 28, 2011, 10 pages (Official Copy Only). (See Communication under 37 CFR § 1.98(a) (3)).

Nozawa et al., "iPhone 4S Perfect Manual", vol. 1, First Edition, Nov. 11, 2011, 5 pages (Official Copy Only) (See Communication under 37 CFR § 1.98(a) (3)).

Okuno et al., "System for Japanese Input Method based on the Internet", Technical Report of Information Processing Society of Japan, Natural Language Processing, Japan, Information Processing Society of Japan, vol. 2009, No. 36, Mar. 18, 2009, 8 pages (Official Copy Only) (See Communication under 37 CFR § 1.98(a) (3)).

Patra et al., "A Kernel-Based Approach for Biomedical Named Entity Recognition", Scientific World Journal, vol. 2013, 2013, pp. 1-7.

(56)

References Cited

OTHER PUBLICATIONS

- Pennington et al., "GloVe: Global Vectors for Word Representation", Proceedings of the Conference on Empirical Methods Natural Language Processing (EMNLP), Oct. 25-29, 2014, pp. 1532-1543.
- Perlow, Jason, "Alexa Loop Mode With Playlist For Sleep Noise", Online Available at: [.youtube.com/watch?v=nSkSuXziJSG](https://www.youtube.com/watch?v=nSkSuXziJSG);, Apr. 11, 2016, 3 pages.
- Samsung Support, "Create a Quick Command in Bixby to Launch Custom Settings by at your Command", Retrieved from internet: [.facebook.com/samsungsupport/videos/10154746303151213](https://www.facebook.com/samsungsupport/videos/10154746303151213), Nov. 13, 2017, 1 page.
- Samsung, "SGH-a885 Series—Portable Quad-Band Mobile Phone-User Manual", Retrieved from the Internet: URL: "<http://web.archive.org/web/20100106113758/http://www.comparecellular.com/images/phones/userguide1896.pdf>", Jan. 1, 2009, 144 pages.
- Seehafer, Brent, "Activate google assistant on Galaxy S7 with screen off", Available online at:—"<https://productforums.google.com/forum/#topic/websearch/lp3qIGBHLVI>", Mar. 8, 2017, 4 pages.
- Selfridge et al., "Interact: Tightly-coupling Multimodal Dialog with an Interactive Virtual Assistant", International Conference on Multimodal Interaction, ACM, Nov. 9, 2015, pp. 381-382.
- Spivack, Nova, "Sneak Preview of Siri—Part Two—Technical Foundations—Interview with Tom Gruber, CTO of Siri", Online Available at <<https://web.archive.org/web/20100114234454/http://www.twine.com/item/12vhy39k4-22m/interview-with-tom-gruber-of-siri>>, Jan. 14, 2010, 5 pages.
- Sundermeyer et al., "From Feedforward to Recurrent LSTM Neural Networks for Language Modeling", IEEE Transactions on Audio, Speech, and Language Processing, 2015, vol. 23, Mar. 2015, pp. 517-529.
- Sundermeyer et al., "LSTM Neural Networks for Language Modeling", Interspeech 2012, ISCA's 13th Annual Conference, Sep. 9-13, 2012, pp. 194-197.
- Tanaka, Tatsuo, "Next Generation IT Channel Strategy Through "Experience Technology"", Intellectual Resource Creation, Japan, Nomura Research Institute Ltd. vol. 19, No. 1, Dec. 20, 2010, 17 pages. (Official Copy only) (See Communication under 37 CFR § 1.98(a) (3)).
- Vodafone Deutschland, "Samsung Galaxy S3 Tastatur Spracheingabe, Available online at—[.youtube.com/watch?v=6kOd6Gr8uFE](https://www.youtube.com/watch?v=6kOd6Gr8uFE)", Aug. 22, 2012, 1 page.
- Wikipedia, "Siri", Available At: URL: <<https://en.wikipedia.org/w/index.php?title=Siri&oldid=>>, Nov. 8, 2015, 13 Pages.
- Wikipedia, "Virtual Assistant, Wikipedia, Online Available at : <[https://en.wikipedia.org/w/index.php?title=Virtual assistant&oldid=679330666](https://en.wikipedia.org/w/index.php?title=Virtual%20assistant&oldid=679330666)>, Sep. 3, 2015, 4 Pages."
- Wikipedia, "Home Automation", Available At: [https://en.wikipedia.org/w/index.php?title= Home automation&oldid=](https://en.wikipedia.org/w/index.php?title=Home%20automation&oldid=), Oct. 19, 2015, 9 pages.
- X.AI, "How it Works", May 2016, 6 pages.
- Xu, Yuhong, "Policy optimization of dialogue management in spoken dialogue system for out-of-domain utterances", 2016 International Conference on Asian Language Processing (IALP), IEEE, Nov. 21, 2016, pp. 10-13.
- Yan et al., "A Scalable Approach to Using DNN-Derived Features in GMM-HMM Based Acoustic Modeling for LVCSR", InInterspeech, 2013, pp. 104-108.
- Yates, Michael C., "How can I exit Google Assistant after i'm finished with it", Available online at:—"<https://productforums.google.com/forum/#!msg/phone-by-google/faECnR2RJwA/gKNtOkQgAQAJ>", Jan. 11, 2016, 2 pages.
- Young et al., "The Hidden Information State model: A practical framework for POMDP-based spoken dialogue management", Computer Speech & Language, vol. 24, Issue 2, 2010, pp. 150-174.
- Zangerle et al., "Recommending #-Tag in Twitter", Proceedings of the Workshop on Semantic Adaptive Social Web, 2011, pp. 1-12.
- "Alexa, Turn Up the Heat!", Smartthings Samsung [online], Available online at <https://web.archive.org/web/20160329142041/https://blog.smartthings.com/news/smartthingsupdates/alexa-turn-up-the-heat/>, Mar. 3, 2016, 3 pages.
- "SmartThings +Amazon Echo", Smartthings Samsung [online], Available online at <<https://web.archive.org/web/20160509231428/https://blog.smartthings.com/featured/alexa-turn-on-my-smartthings/>>, Aug. 21, 2015, 3 pages.
- Adium, "AboutAdium—Adium X—Trac", available at <<http://web.archive.org/web/20070819113247/http://trac.adiumx.com/wiki/AboutAdium>>, retrieved on Nov. 25, 2011, 2 pages.
- Alfred App, "Alfred", available at <alfredapp.com/>, retrieved on Feb. 8, 2012, 5 pages.
- Anania, Peter, "Amazon Echo with Home Automation (Smartthings)", Available online at [youtube.com/watch?v=LMW6aXmsWNE](https://www.youtube.com/watch?v=LMW6aXmsWNE), Dec. 20, 2015, 1 page.
- API.AI, "Android App Review—Speaktoit Assistant", Available at <[youtube.com/watch?v=myE498nyfGw](https://www.youtube.com/watch?v=myE498nyfGw)>, Mar. 30, 2011, 3 pages.
- Apple, "VoiceOver", available at <apple.com/accessibility/voiceover/>, May 19, 2014, 3 pages.
- Berry et al., "Ptime: Personalized Assistance for Calendaring", ACM Transactions on Intelligent Systems and Technology, vol. 2, No. 4, Article 40, Jul. 2011, pp. 1-22.
- Bertulucci, Jeff, "Google Adds Voice Search to Chrome Browser", PC World, Jun. 14, 2011, 5 pages.
- Bocchieri et al., "Use of Geographical Meta-Data in ASR Language and Acoustic Models", IEEE International Conference on Acoustics Speech and Signal Processing, 2010, pp. 5118-5121.
- Butcher, Mike, "Evi Arrives in Town to go Toe-to-Toe with Siri", TechCrunch, Jan. 23, 2012, 2 pages.
- Caraballo et al., "Language Identification Based on a Discriminative Text Categorization Technique", Iberspeech 2012—VII Jornadas En Tecnologia Del Habla And Iii Iberiansl Tech Workshop, Nov. 21, 2012, pp. 1-10.
- Castleos, "Whole House Voice Control Demonstration", available online at : [youtube.com/watch?v=9SRCoXrZ_W4](https://www.youtube.com/watch?v=9SRCoXrZ_W4), Jun. 2, 2012, 26 pages.
- Chen, Yi, "Multimedia Siri Finds and Plays Whatever You Ask For", PSFK Report, Feb. 9, 2012, 9 pages.
- Cheyner, Adam, "About Adam Cheyner", available at <adam.cheyner.com/about.html>, retrieved on Sep. 17, 2012, 2 pages.
- Choi et al., "Acoustic and Visual Signal based Context Awareness System for Mobile Application", IEEE Transactions on Consumer Electronics, vol. 57, No. 2, May 2011, pp. 738-746.
- Colt, Sam, "Here's One Way Apple's Smartwatch Could Be Better Than Anything Else", Business Insider, Aug. 21, 2014, pp. 1-4.
- Deedeuvu, "Amazon Echo Alarm Feature", Available online at [.youtube.com/watch?v=fdjU8eRLk7c](https://www.youtube.com/watch?v=fdjU8eRLk7c), Feb. 16, 2015, 1 page.
- Evi, "Meet Evi: The One Mobile Application that Provides Solutions for your Everyday Problems", Feb. 2012, 3 pages.
- Exhibit I, "Natural Language Interface Using Constrained Intermediate Dictionary of Results", List of Publications Manually Reviewed for the Search of U.S. Pat. No. 7,177,798, Mar. 22, 2013, 1 page.
- Findlater et al., "Beyond QWERTY: Augmenting Touch-Screen Keyboards with Multi-Touch Gestures for Non-Alphanumeric Input", CHI '12, Austin, Texas, USA, May 5-10, 2012, 4 pages.
- Final Office Action received for U.S. Appl. No. 11/518,292, dated May 10, 2011, 14 pages.
- Final Office Action received for U.S. Appl. No. 11/518,292, dated May 18, 2010, 13 pages.
- Final Office Action received for U.S. Appl. No. 14/141,261, dated Apr. 23, 2015, 19 pages.
- Final Office Action received for U.S. Appl. No. 15/299,264, dated Jul. 16, 2018, 18 pages.
- Gannes, Liz, "Alfred App Gives Personalized Restaurant Recommendations", AllThingsD, Jul. 18, 2011, pp. 1-3.
- Gomez et al., "Mouth Gesture and Voice Command Based Robot Command Interface", IEEE International Conference on Robotics and Automation, May 12-17, 2009, pp. 333-338.
- Gruber, Thomas R., et al., U.S. Appl. No. 61/186,414, filed Jun. 12, 2009 titled "System and Method for Semantic Auto-Completion" 13 pages.
- Gruber, Tom, "Big Think Small Screen: How Semantic Computing in the Cloud will Revolutionize the Consumer Experience on the Phone", Keynote Presentation at Web 3.0 Conference, Jan. 2010, 41 pages.

(56)

References Cited

OTHER PUBLICATIONS

- Gruber, Tom, "Siri, A Virtual Personal Assistant-Bringing Intelligence to the Interface", Semantic Technologies Conference, Jun. 16, 2009, 21 pages.
- Guay, Matthew, "Location-Driven Productivity with Task Ave", available at <<http://iphone.appstorm.net/reviews/productivity/location-driven-productivity-with-task-ave/>>, Feb. 19, 2011, 7 pages.
- Guim, Mark, "How to Set a Person-Based Reminder with Cortana", available at <wpcentral.com/how-to-person-based-reminder-cortana>, Apr. 26, 2014, 15 pages.
- Hardwar, Devindra, "Driving App Waze Builds its own Siri for Hands-Free Voice Control", Available online at <<http://venturebeat.com/2012/02/09/driving-app-waze-builds-its-own-siri-for-hands-free-voice-control/>>, retrieved on Feb. 9, 2012, 4 pages.
- Hashimoto, Yoshiyuki, "Simple Guide for iPhone Siri, Which Can Be Operated with Your Voice", Shuwa System Co., Ltd., vol. 1, Jul. 5, 2012, pp. 8, 130, 131.
- Headset Button Controller v7.3 APK Full App Download for Android, Blackberry, iPhone, Jan. 27, 2014, 11 pages.
- Hear voice from Google translate, Available on URL:<https://youtube.com/watch?v=18AvMhFqD28>, Jan. 28, 2011, 1 page.
- id3.org, "id3v2.4.0-Frames", available at <<http://id3.org/id3v2.4.0-frames?action=print>>, retrieved on Jan. 22, 2015, 41 pages.
- Interactive Voice, available at <helloivee.com/company/>, retrieved on Feb. 10, 2014, 2 pages.
- Iowegian International, "FIR Filter Properties, DSPGuru, Digital Signal Processing Central", available at <dspguru.com/dsp/faq/fir/properties> retrieved on Jul. 28, 2010, 6 pages.
- Jawaid et al., "Machine Translation with Significant Word Reordering and Rich Target-Side Morphology", WDS'11 Proceedings of Contributed Papers, Part I, 2011, pp. 161-166.
- Jiang et al., "A Syllable-based Name Transliteration System", Proc. of the 2009 Named Entities Workshop, Aug. 7, 2009, pp. 96-99.
- Jouvet et al., "Evaluating Grapheme-to-phoneme Converters in Automatic Speech Recognition Context", IEEE, 2012, pp. 4821-4824.
- Kazmucha, Allyson, "How to Send Map Locations Using iMessage", iMore.com, Available at <<http://www.imore.com/how-use-imeessage-share-your-location-your-iphone>>, Aug. 2, 2012, 6 pages.
- Kickstarter, "Ivee Sleek: Wi-Fi Voice-Activated Assistant", available at <kickstarter.com/projects/ivee/ivee-sleek-wi-fi-voice-activated-assistant>, retrieved on Feb. 10, 2014, 13 pages.
- Lewis, Cameron, "Task Ave for iPhone Review", Mac Life, Available at <maclife.com/article/reviews/task_ave_iphone_review>, Mar. 3, 2011, 5 pages.
- Meet Ivee, Your Wi-Fi Voice Activated Assistant, available at <helloivee.com/>, retrieved on Feb. 10, 2014, 8 pages.
- Mel Scale, Wikipedia the Free Encyclopedia, Last modified on Oct. 13, 2009 and retrieved on Jul. 28, 2010, available at <http://en.wikipedia.org/wiki/Mel_scale>, 2 pages.
- Microsoft, "Turn On and Use Magnifier", available at <microsoft.com/windowsxp/using/accessibility/magnifierturnon.mspx>, retrieved on Jun. 6, 2009.
- Miller, Chance, "Google Keyboard Updated with New Personalized Suggestions Feature", available at <<http://9to5google.com/2014/03/19/google-keyboard-updated-with-new-personalized-suggestions-feature/>>, Mar. 19, 2014, 4 pages.
- Minimum Phase, Wikipedia the free Encyclopedia, Last modified on Jan. 12, 2010 and retrieved on Jul. 28, 2010, available at <http://en.wikipedia.org/wiki/Minimum_phase>, 8 pages.
- Mitra et al., "A Graph-Oriented Model for Articulation of Ontology Interdependencies", Advances in Database Technology, Lecture Notes in Computer Science, vol. 1777, 2000, pp. 1-15.
- Mobile Speech Solutions, Mobile Accessibility, Svov AG Product Information Sheet, available at <svov.com/site/bra840604/con782768/mob965831936.aSQ?osLang=1>, Sep. 27, 2012, 1 page.
- My Cool Aids, "What's New", available at <<http://www.mycoolaids.com/>>, 2012, 1 page.
- Myers, Brad A., "Shortcutter for Palm", available at <cs.cmu.edu/~pebbles/v5/shortcutter/palm/index.html>, retrieved on Jun. 18, 2014, 10 pages.
- Naone, Erica, "TR10: Intelligent Software Assistant", Technology Review, Mar.-Apr. 2009, 2 pages.
- Navigli, Roberto, "Word Sense Disambiguation: A Survey", ACM Computing Surveys, vol. 41, No. 2, Feb. 2009, 69 pages.
- NDTV, "Sony SmartWatch 2 Launched in India for Rs. 14,990", available at <<http://gadgets.ndtv.com/others/news/sony-smartwatch-2-launched-in-india-for-rs-14990-420319>>, Sep. 18, 2013, 4 pages.
- Ng, Simon, "Google's Task List Now Comes to iPhone", SimonBlog, Available at <simonblog.com/2009/02/04/googles-task-list-now-comes-to-iphone/>, Feb. 4, 2009, 3 pages.
- Non-Final Office Action received for U.S. Appl. No. 11/518,292, dated Nov. 24, 2010, 12 pages.
- Non-Final Office Action received for U.S. Appl. No. 11/518,292, dated Nov. 9, 2009, 10 pages.
- Non-Final Office Action received for U.S. Appl. No. 14/141,261, dated Oct. 22, 2014, 17 pages.
- Non-Final Office Action received for U.S. Appl. No. 15/299,264, dated Dec. 13, 2017, 13 pages.
- Notice of Allowance received for U. S. U.S. Appl. No. 11/518,292, dated Feb. 29, 2012, 17 pages.
- Notice of Allowance received for U.S. Appl. No. 11/518,292, dated Jun. 12, 2013, 7 pages.
- Notice of Allowance received for U.S. Appl. No. 11/518,292, dated Nov. 6, 2013, 7 pages.
- Notice of Allowance received for U.S. Appl. No. 14/141,261, dated Jul. 18, 2016, 9 pages.
- Notice of Allowance received for U.S. Appl. No. 15/299,264, dated Jan. 9, 2019, 9 pages.
- Osxdaily, "Get a List of Siri Commands Directly from Siri", Available at <<http://osxdaily.com/2013/02/05/list-siri-commands/>>, Feb. 5, 2013, 15 pages.
- Pan et al., "Natural Language Aided Visual Query Building for Complex Data Access", In proceeding of: Proceedings of the Twenty-Second Conference on Innovative Applications of Artificial Intelligence, XP055114607, Jul. 11, 2010, pp. 1821-1826.
- Pathak et al., "Privacy-preserving Speech Processing: Cryptographic and String-matching Frameworks Show Promise", In: IEEE signal processing magazine, retrieved from <<http://www.merl.com/publications/docs/TR2013-063.pdf>>, Feb. 13, 2013, 16 pages.
- Phoenix Solutions, Inc., "Declaration of Christopher Schmandt Regarding the MIT Galaxy System", West Interactive Corp., A Delaware Corporation, Document 40, Jul. 2, 2010, 162 pages.
- Pollock, Stephen, "A Rule-Based Message Filtering System", Published in: Journal, ACM Transactions on Information Systems (TOIS), vol. 6, Issue 3, Jul. 1988, pp. 232-254.
- Powell, Josh, "Now You See Me . . . Show/Hide Performance", available at <learningjquery.com/2010/05/now-you-see-me-showhide-performance>, May 4, 2010, 3 pages.
- Reddi, "The Parser".
- Rios, Mafe, "New bar search for Facebook", Youtube, available at <youtube.com/watch?v=vwgN1WbvCas>, Jul. 19, 2013, 2 pages.
- Routines, "SmartThings Support", Available online at <<https://web.archive.org/web/20151207165701/https://support.smartthings.com/hc/en-us/articles/205380034-Routines>>, 2015, 2 pages.
- Sarawagi, Sunita, "CRF Package Page", available at <<http://crf.sourceforge.net/>>, retrieved on Apr. 6, 2011, 2 pages.
- Simonite, Tom, "One Easy Way to Make Siri Smarter", Technology Review, Oct. 18, 2011, 2 pages.
- Speaker Recognition, Wikipedia, The Free Encyclopedia, Nov. 2, 2010, 4 pages.
- SRI, "SRI Speech: Products: Software Development Kits: EduSpeak", available at <<http://web.archive.org/web/20090828084033/http://www.speechsri.com/products/eduspeak.shtml>>, retrieved on Jun. 20, 2013, 2 pages.
- Stent et al., "Geo-Centric Language Models for Local Business Voice Search", AT&T Labs—Research, 2009, pp. 389-396.
- Sullivan, Danny, "How Google Instant's Autocomplete Suggestions Work", available at <<http://searchengineland.com/how-google-instant-autocomplete-suggestions-work-62592>>, Apr. 6, 2011, 12 pages.

(56)

References Cited

OTHER PUBLICATIONS

Sundaram et al., "Latent Perceptual Mapping with Data-Driven Variable-Length Acoustic Units for Template-Based Speech Recognition", ICASSP 2012, Mar. 2012, pp. 4125-4128.

Supplemental Notice of Allowance received for U.S. Appl. No. 11/518,292, dated Jan. 24, 2014, 2 pages.

Supplemental Notice of Allowance received for U.S. Appl. No. 11/518,292, dated Jul. 9, 2013, 2 pages.

TextnDrive, "Text'nDrive App Demo-Listen and Reply to your Messages by Voice while Driving!", YouTube Video available at <<http://www.youtube.com/watch?v=WaGfzoHsAMw>>, Apr. 27, 2010, 1 page.

Tofel, Kevin C., "SpeakTolt: A Personal Assistant for Older iPhones, iPads", Apple News, Tips and Reviews, Feb. 9, 2012, 7 pages.

Tucker, Joshua, "Too Lazy to Grab Your TV Remote? Use Siri Instead", Engadget, Nov. 30, 2011, 8 pages.

Tur et al., "The CALO Meeting Assistant System", IEEE Transactions on Audio, Speech and Language Processing, vol. 18, No. 6, Aug. 2010, pp. 1601-1611.

Vlingo InCar, "Distracted Driving Solution with Vlingo InCar", YouTube Video, Available online at youtube.com/watch?v=Vqs8XfXgz4, Oct. 2010, 2 pages.

Voiceassist, "Send Text, Listen to and Send E-Mail by Voice", YouTube Video, Available online at <youtube.com/watch?v=0tEU61nHHA4>, Jul. 30, 2009, 1 page.

VoiceontheGo, "Voice on the Go (BlackBerry)", YouTube Video, available online at <youtube.com/watch?v=pJqpWgQS98w>, Jul. 27, 2009, 1 page.

Wikipedia, "Acoustic Model", available at <<http://en.wikipedia.org/wiki/AcousticModel>>, retrieved on Sep. 14, 2011, 2 pages.

Wikipedia, "Language Model", available at <http://en.wikipedia.org/wiki/Language_model>, retrieved on Sep. 14, 2011, 4 pages.

Wikipedia, "Speech Recognition", available at <http://en.wikipedia.org/wiki/Speech_recognition>, retrieved on Sep. 14, 2011, 12 pages.

Wilkins et al., "Interactive Execution Monitoring of Agent Teams", Journal of Artificial Intelligence Research, vol. 18, 2003, pp. 217-261.

Wilson, Mark, "New iPod Shuffle Moves Buttons to Headphones, Adds Text to Speech", available at <<http://gizmodo.com/5167946/new-ipod-shuffle-moves-buttons-to-headphones-adds-text-to-speech>>, Mar. 11, 2009, 12 pages.

Xiang et al., "Correcting Phoneme Recognition Errors in Learning Word Pronunciation through Speech Interaction", Speech Communication, vol. 55, No. 1, Jan. 1, 2013, pp. 190-203.

Xu et al., "Speech-Based Interactive Games for Language Learning: Reading, Translation, and Question-Answering", Computational Linguistics and Chinese Language Processing, vol. 14, No. 2, Jun. 2009, pp. 133-160.

Zainab, "Google Input Tools Shows Onscreen Keyboard in Multiple Languages [Chrome]", available at [.addictivetips.com/internet-tips/google-input-tools-shows-multiple-language-onscreen-keyboards-chrome/](http://addictivetips.com/internet-tips/google-input-tools-shows-multiple-language-onscreen-keyboards-chrome/), Jan. 3, 2012, 3 pages.

Zhang et al., "Research of Text Classification Model Based on Latent Semantic Analysis and Improved HS-SVM", Intelligent Systems and Applications (ISA), 2010 2nd International Workshop, May 22-23, 2010, 5 pages.

Zhong et al., "JustSpeak: Enabling Universal Voice Control on Android", W4A'14, Proceedings of the 11th Web for All Conference, No. 36, Apr. 7-9, 2014, 8 pages.

Corrected Notice of Allowance received for U.S. Appl. No. 15/299,264, dated May 10, 2019, 3 pages.

* cited by examiner

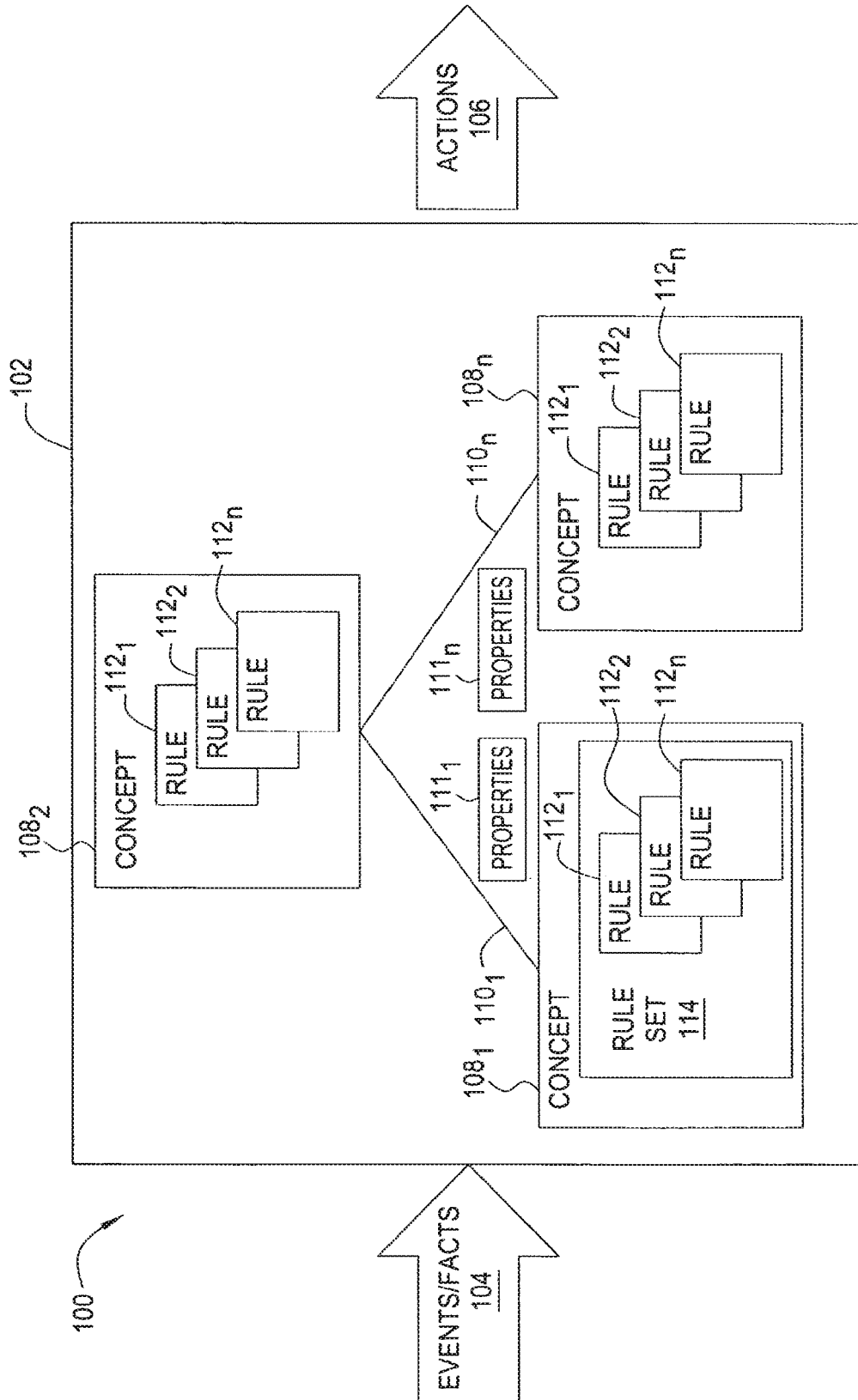

FIG. 1

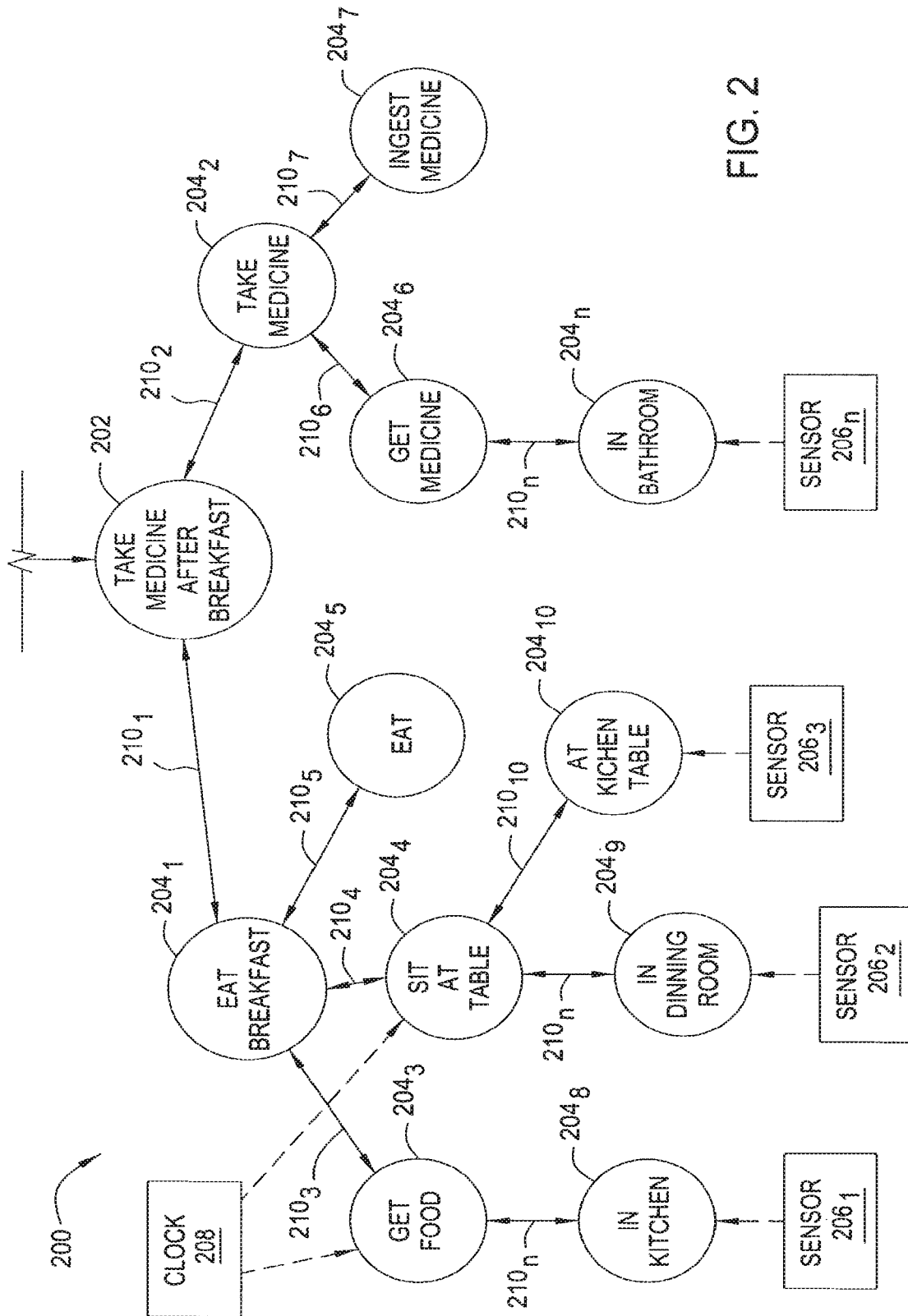

FIG. 2

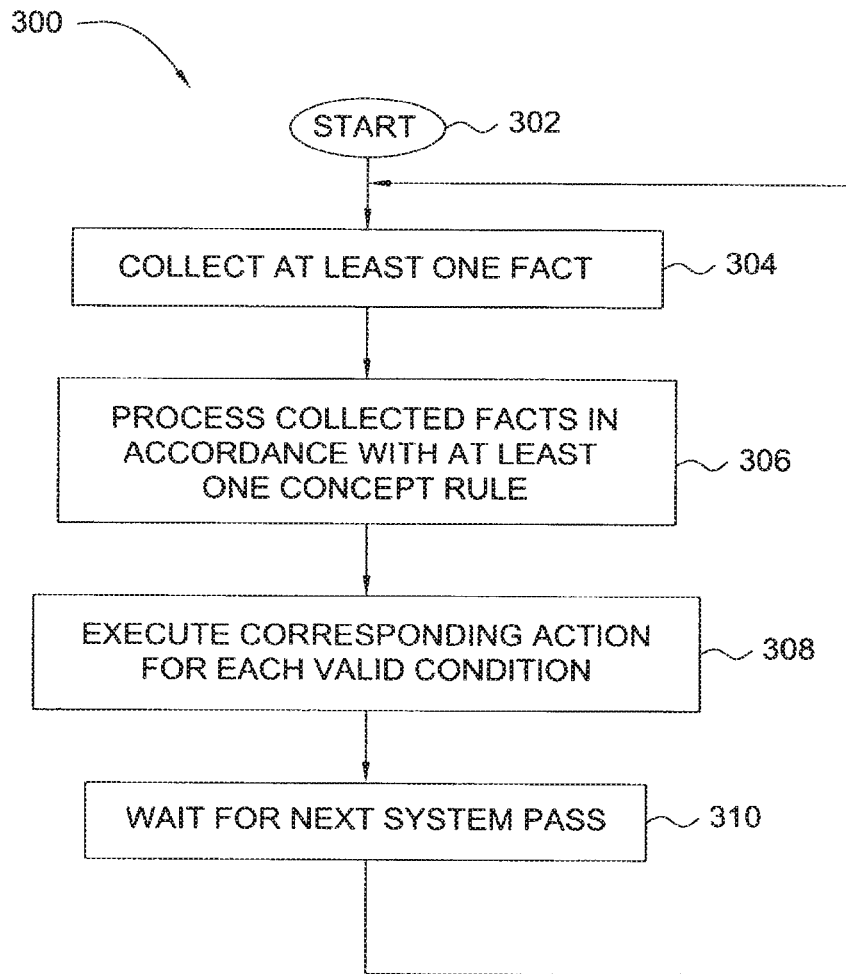

FIG. 3

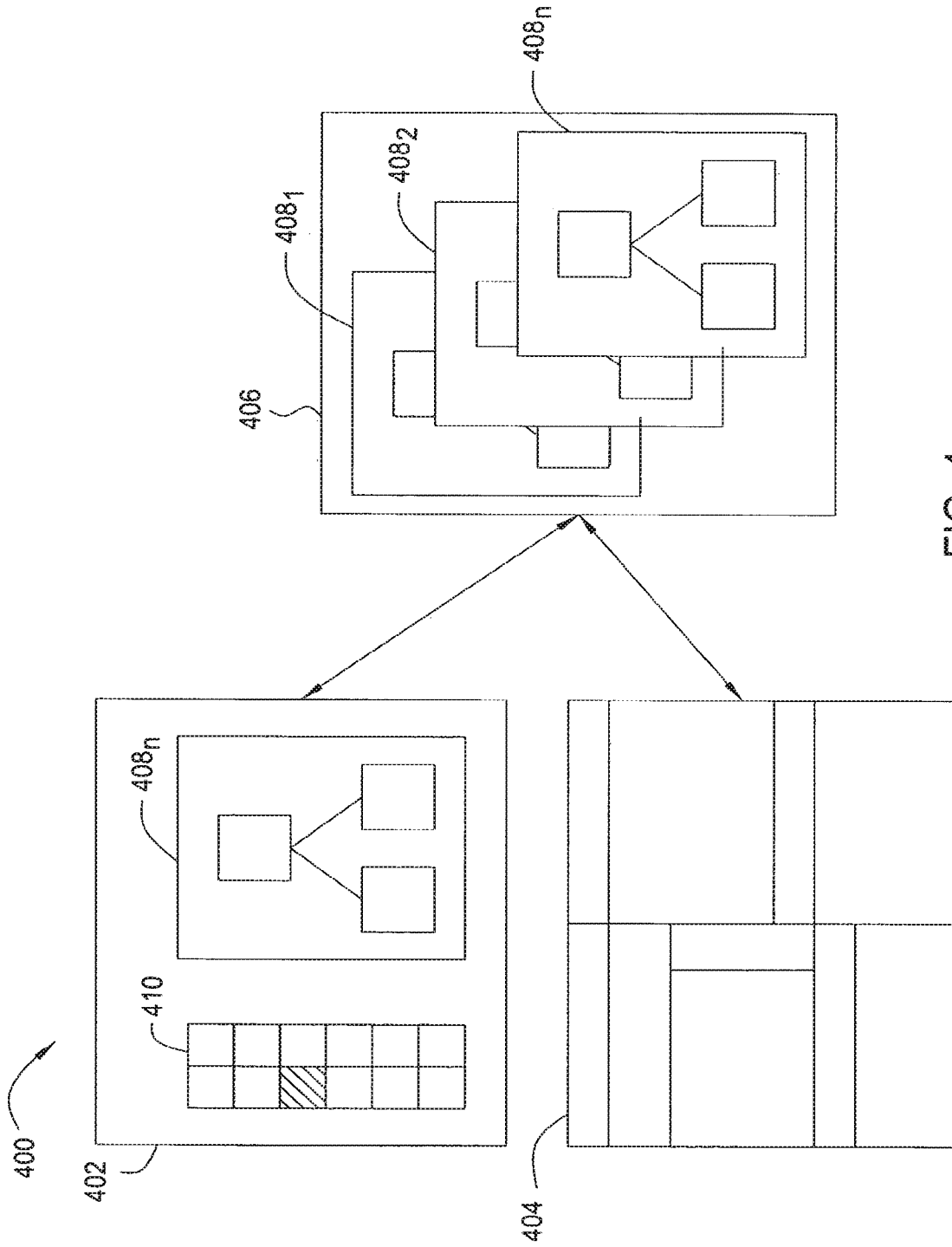

FIG. 4

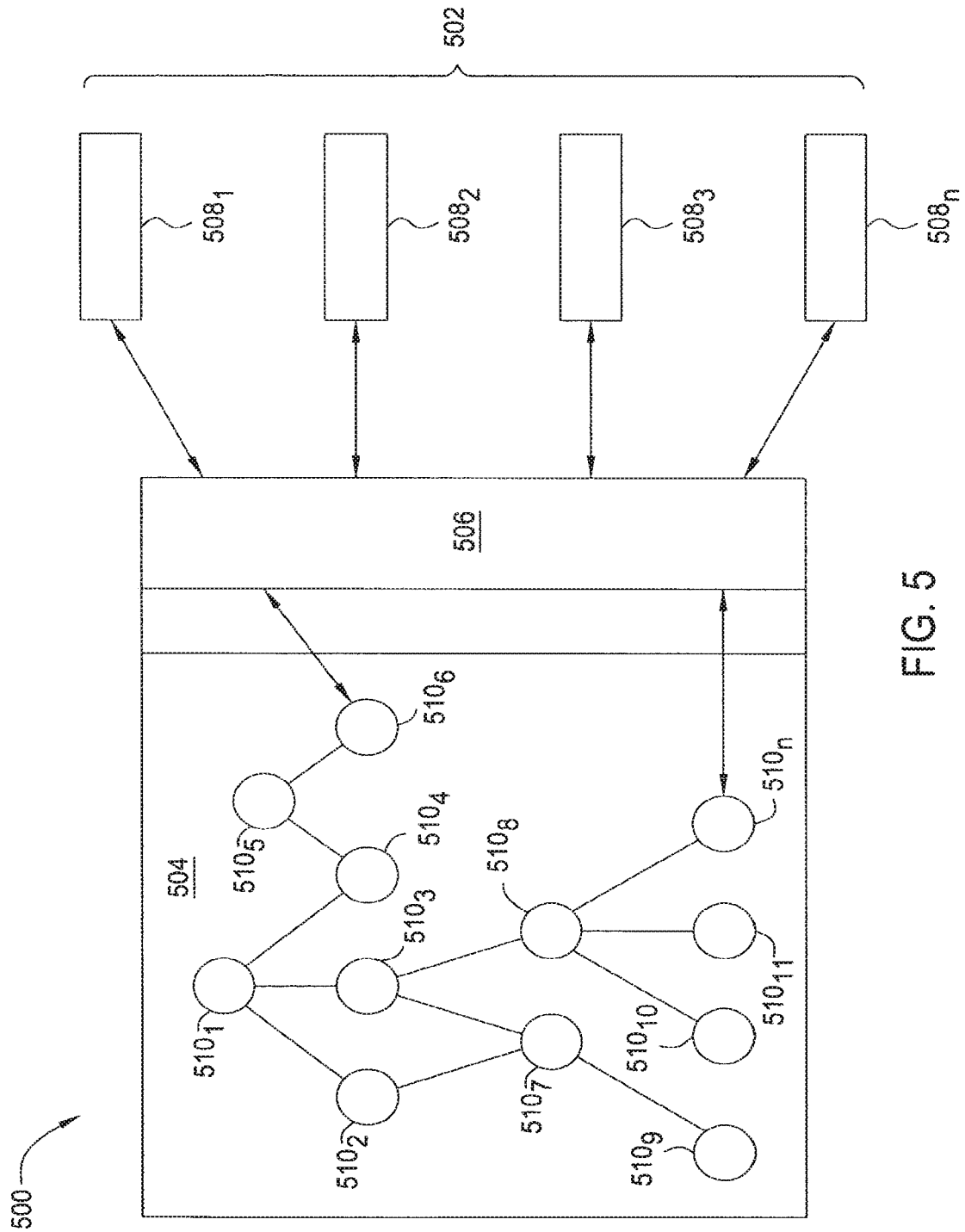

FIG. 5

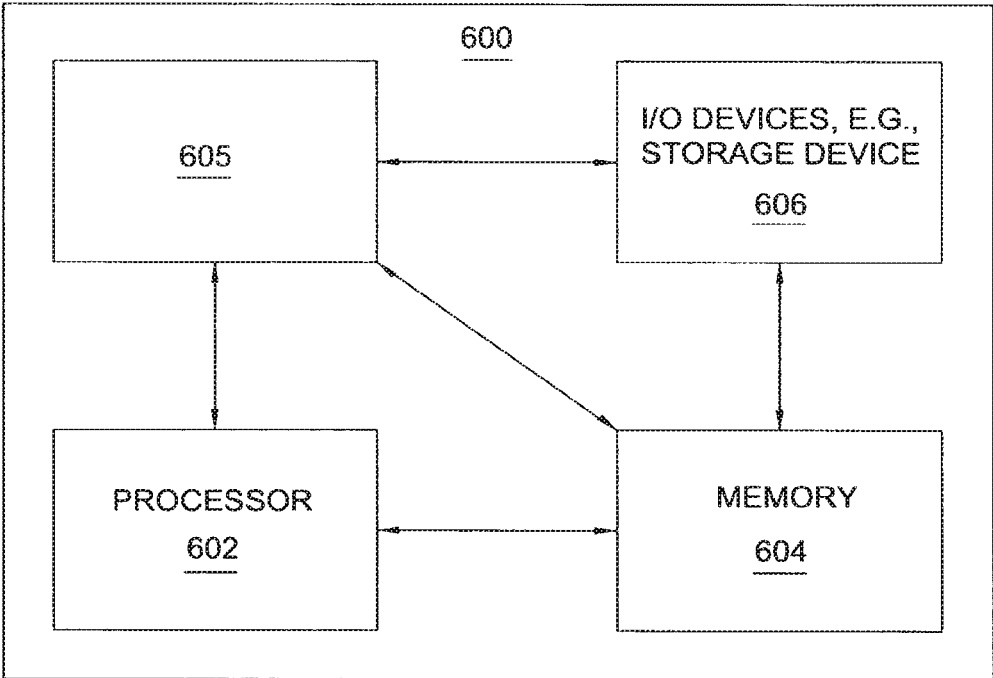

FIG. 6

METHOD AND APPARATUS FOR BUILDING AN INTELLIGENT AUTOMATED ASSISTANT

CROSS REFERENCE TO RELATED APPLICATIONS

This application is a continuation of U.S. application Ser. No. 15/299,264, filed Oct. 20, 2016, which is a continuation of U.S. application Ser. No. 14/141,261, filed on Dec. 26, 2013, which is a continuation of U.S. application Ser. No. 11/518,292, filed Sep. 8, 2006, which claims the benefit of U.S. Provisional Patent Application Ser. No. 60/715,324, filed Sep. 8, 2005. The contents of all applications are herein incorporated by reference in their entirety.

FIELD OF THE INVENTION

The invention relates generally to intelligent systems and relates more specifically to tools for building classes of applications for intelligent automated assistants.

BACKGROUND OF THE DISCLOSURE

Intelligent systems, such as intelligent automated assistants, that are capable of interacting with humans (e.g., by observing user behavior, communicating with users, understanding observed situations, anticipating what a user may need and acting to produce useful behavior) are valuable in a variety of situations. For example, such systems may assist individuals who are impaired in some way (e.g., visually, auditorially, physically, cognitively, etc.), including elderly people (who may be stricken by one or more ailments), surgeons (whose eyes, hands and brains are constantly busy/when performing operations) and business executives (who may have numerous tasks to accomplish), among others.

To accomplish all of these objectives, intelligent automated assistants integrate a variety of capabilities provided by different software components (e.g., for supporting natural language recognition, multimodal input, managing distributed services, etc.). Development of a system incorporating these different software components typically requires knowledge of numerous different programming languages and artificial intelligence-based methods. Thus, the development of an intelligent automated assistant is a complex task that typically requires contribution from a plurality of highly skilled individuals each having expertise in different aspects of programming; it is nearly impossible for a lone software developer to build an intelligent automated assistant due to the breadth and variety of expertise that is required to build the system. The typical development process for building intelligent automated assistants is therefore relatively inefficient in terms of time, cost and manpower.

Thus, there is a need in the art for a method and apparatus for building an intelligent automated assistant.

SUMMARY OF THE INVENTION

A method and apparatus are provided for building an intelligent automated assistant. Embodiments of the present invention rely on the concept of “active ontologies” (e.g., execution environments constructed in an ontology-like manner) to build and run applications for use by intelligent automated assistants. In one specific embodiment, a method for building an automated assistant includes interfacing a service-oriented architecture that includes a plurality of

remote services to an active ontology, where the active ontology includes at least one active processing element that models a domain. At least one of the remote services is then registered for use in the domain.

BRIEF DESCRIPTION OF THE DRAWINGS

FIG. 1 is a schematic diagram illustrating one embodiment of an active ontology execution environment according to the present invention;

FIG. 2 is a schematic diagram illustrating one embodiment of an exemplary active ontology that is configured as an autominder for reminding a user to take medicine after meals (e.g., configured for activity and/or time recognition);

FIG. 3 is a flow diagram illustrating one embodiment of a method for processing facts in accordance with an active ontology (e.g., configured in a manner similar to the active ontology of FIG. 1) according to the present invention;

FIG. 4 is a schematic diagram illustrating one embodiment of an open standard-based system for developing and managing an intelligent system using active ontologies;

FIG. 5 is a schematic diagram illustrating one embodiment of a framework for dynamically registering and coordinating distributed services using active ontologies; and

FIG. 6 is a high level block diagram of the present intelligent system building method that is implemented using a general purpose computing device.

DETAILED DESCRIPTION

In one embodiment, the present invention is a method and apparatus for building an intelligent automated assistant. Embodiments of the present invention rely on a developer-friendly unified framework, referred to as an “active ontology”, which integrates multiple system-building capabilities in a single tool. An “ontology”, generally, is a passive data structure that represents domain knowledge, where distinct classes, attributes and relations among classes are defined. A separate engine may operate or reason on this data structure to produce certain results. Within the context of the present invention, an “active ontology” may be thought of as an execution environment in which distinct processing elements are arranged in an ontology-like manner (e.g., having distinct attributes and relations with other processing elements). These processing elements carry out at least some of the typical tasks of an intelligent automated assistant. Although described within the context of an intelligent automated assistant, it will be understood that the concepts of the present invention may be implemented in accordance with any application that involves interaction with software.

FIG. 1 is a schematic diagram illustrating one embodiment of an active ontology execution environment **100** according to the present invention. The execution environment comprises an active ontology **102** that is adapted to receive one or more input facts or events **104** and process these inputs **104** to produce useful actions **106**. In one embodiment, the active ontology **102** is tailored to a specific context. For example, the active ontology **102** may be adapted to remind a user to take medication after meals, where at least some of the input facts **104** relate to events collected from the user’s surrounding environment (e.g., “the user is in the kitchen”, “the user is eating”, “the time is 8:00 AM”, etc.) and at least one of the actions **106** is produced in response to these facts (e.g., prompting the user to take the medication at the appropriate time).

To this end, the active ontology **102** comprises at least one active processing element or concept **108₁-108_n**, (hereinafter

collectively referred to as “concepts **108**”). The concepts **108** may be thought of as the basic building block of the active ontology **102**; concepts **108** both represent a sub-part of the execution environment **100** and perform computations or actions (e.g., natural language understanding, task execution, etc.) related to the sub-part. Concepts **108** are adapted to match to specific types of facts in order to perform these actions, and may be specifically configured to manage temporal constraints, service brokering strategies, fusion strategies, or other tasks.

In one embodiment, the concepts **108** are prioritized such that the input facts **104** are processed against the concepts **108** starting with a highest-ranked concept **108** and proceeding in descending order to a lowest-ranked concept **108**. In one embodiment, at least two of the concepts **108** are communicatively coupled by a channel **110₁-110_n** (hereinafter collectively referred to as “channels **110**”) that allows the concepts **108** to communicate and to share information. For example, concepts **108** may share all or part of their respective computation results with other concepts **108** over these channels **110**. In this case, information propagated using the channels **110** may be weighted or associated with a probability such that joining concepts **108** may use these weights or probabilities when determining how further results derived from incoming information should be propagated.

In one embodiment, channels **110** possess properties **111₁-111_n** (hereinafter referred to as “properties **111**”) that configure the relationship expressed between connected concepts. For example, a property “Mandatory” associated with a channel that connects a first concept and a second concept may express that the first concept cannot be valid if the second concept is not satisfied. Thus, for instance, if the first concept represents “MovieListing”, and the second concept represents “GeographicalArea”, the “Mandatory” property expresses that a user cannot request a MovieListing (e.g., “Find action movies starring actor X”) without also supplying a geographical location (“e.g., near San Francisco”).

Each concept **108** comprises a template including at least one rule **112₁-112_n** (hereinafter collectively referred to as “rules **112**”) or rule set **114** (comprising multiple rules **112**). Each rule **112** comprises a condition and an associated action. If an input fact matches a rule’s condition, the associated action is triggered. In one embodiment, conditions may be evaluated as Java Script Boolean expressions (e.g., comprising slots), while associated actions are executed as Java Script programs. In further embodiment, rules **112** are prioritized within each concept **108** so that the rules are processed in an order of descending priority. Prioritization of rules allows for applications including activity recognition and action validation to share a common ontology structure. For example, a decision tree may be traversed in one direction for action execution, and then traversed in the opposite direction for action validation.

Among other advantages, active ontologies such as those described above can enable a simplified, efficient development scheme for intelligent automated assistants. Such a framework can be implemented to tie together multiple different programming applications, including applications capable of processing multimodal input, generating adaptable presentations, producing natural language dialogues, performing reactive planning, performing activity recognition and/or scheduling, and brokering, registering and coordinating distributed services, in a unified, visual framework. Thus, a single software developer may quickly and easily

build an intelligent automated assistant using such a unified, developer-friendly development scheme.

As described in further detail with respect to FIG. 3, an active ontology such as the active ontology **100** may be built to process facts in order to achieve any one of a number of goals, including activity recognition (e.g., natural language processing, human activity recognition, etc.), reactive activity execution (e.g., pseudo-reactive planning, rule-based planning, etc.) and management of temporal constraints (e.g., for activity execution times), among others. A plurality of individual active ontologies may be built to execute a plurality of different goals, and these individual active ontologies may be integrated into a single processing unit such as an intelligent automated assistant. As described further below, these active ontologies may be managed in a manner that is significantly simpler than the traditional development process for intelligent automated assistants.

FIG. 2 is a schematic diagram illustrating one embodiment of an exemplary active ontology **200** that is configured as an assistant for reminding a user to take medicine after meals (e.g., configured for activity and/or time recognition). As illustrated, the active ontology **200** comprises at least one target task **202** (e.g., “take medicine after breakfast”) and a plurality of concepts **204₁-204_n** (hereinafter collectively referred to as “concepts **204**”) representing potential user actions related to the target task **202** and to the modeled domain in which these actions are likely to occur (e.g., the user’s home). The concepts **204** are communicatively coupled to other concepts **204** via a plurality of channels **210₁-210_n** (hereinafter collectively referred to as “channels **210**”).

The active ontology **200** is also in communication with a plurality of sensors **206₁-206_n** (hereinafter collectively referred to as “sensors **206**”) that are distributed throughout the modeled domain and are adapted to convey observed facts relating to the user’s behavior (e.g., “the user is in the kitchen”; “the user is in the dining room”; “the user is in the bathroom”; etc.) to the higher-level concepts **204** for appropriate processing. Concepts **204** also communicate processing results (or at least partial processing results) to other concepts for further processing (e.g., if concept **204₈** verifies that the user is in the kitchen, concept **204₈** may convey this information to concept **204₃**, which is configured to determine whether the user is getting food). In addition, a clock **208** may also be in communication with the concepts **204** to enable the management of temporal constraints (e.g., the user is expected to sit at the table for approximately twenty-five minutes while eating breakfast; the user should take his/her medicine approximately thirty minutes after finishing breakfast; etc.).

Thus, if the target task **202** is not observed as being executed (e.g., the active ontology **200** does not determine that the user has taken the medicine after a meal or within a predefined period of time after finishing a meal), one or more of the processing elements (concepts **204**) may generate a reminder to prompt the user to perform the target task **202**. Although the active ontology **200** illustrated in FIG. 2 is configured to manage activity and time recognition tasks, those skilled in the art will appreciate that similarly constructed active ontologies may be built for natural language recognition, task automation and other useful tasks. In general, the same structure or rule or set of rules can be used both to observe and understand the surrounding world and to act on such observations.

FIG. 3 is a flow diagram illustrating one embodiment of a method **300** for processing facts in accordance with an active ontology (e.g., configured in a manner similar to the

active ontology **100** of FIG. 1) according to the present invention. The method **300** may be executed at, for example, an intelligent automated assistant that interacts with a user in accordance with an active ontology.

The method **300** is initialized at step **302** and proceeds to step **304**, where the method **300** collects at least one fact from the operating environment. In one embodiment, facts may be received via sensors (e.g., cameras, motion sensors, environmental and/or physical monitoring devices, etc.) distributed through the operating environment or from other multimodal user interfaces (e.g., a natural language interface, a graphical user interface, etc.). In one embodiment, collected facts are “tagged” upon receipt to identify an associated context and evaluation pass of the method **300**.

In step **306**, the method **300** processes the collected facts in accordance with at least one concept rule to identify valid conditions. In one embodiment, only facts that are associated (or “tagged”) with the current execution pass are processed in step **306**. In one embodiment, concepts are processed in accordance with a predefined order of priority, and rules for each concept are likewise processed in accordance with a predefined order of priority. Thus, step **306** begins by processing relevant facts against the highest priority rule of the highest priority concept, and then processes the facts against the second-highest priority rule of the highest priority concept, and so on until all rules of the highest priority concept have been processed. Step **306** then moves on to the next-highest priority concept and proceeds in a likewise manner.

In one embodiment, processing of facts in accordance with step **306** also includes the sharing of information among concepts (e.g., via channels as described above). The processing priority order described above ensures that higher priority concepts are evaluated first while lower priority concepts are still executable within a common execution pass of the method **300**.

In step **308**, the method **300** executes the corresponding action for each valid condition that is identified in accordance with **306**. The method **300** then proceeds to step **310** and waits for the next execution pass. In one embodiment, the execution passes of the method **300** are predefined such that the method **300** automatically executes at a given pace (e.g., once every x seconds). At the next execution pass, the method **300** returns to step **304** and proceeds as described above to evaluate a new set of facts.

FIG. 4 is a schematic diagram illustrating one embodiment of an open standard-based system **400** for developing and managing an intelligent system using active ontologies. In one embodiment, the system **400** includes an editor **402**, a console **404** and a server **406**. In one embodiment, the editor **402** and the console **404** communicate with the server **506** using SOAP-based communications.

The server **406** is adapted to store a plurality of individual active ontologies **408₁-408_n** (hereinafter collectively referred to as “active ontologies **408**”) and to run selected (deployed) active ontologies **408** in an application domain. In one embodiment, the server **406** also stores observed facts for processing in accordance with an active ontology such as one of the stored or deployed active ontologies **408**. Specifically, these facts may be used to stimulate currently deployed active ontologies **408**. In one embodiment, the server **406** is a stand-alone application (e.g., a Java stand-alone application).

The editor **402** is interfaced to the server **406** and is adapted to retrieve active ontologies **408** from the server **406** for editing. Specifically, the editor **402** is adapted to edit the concepts and/or rules embodied in the active ontologies **408**

and to deploy or remove active ontologies **408** from use. To this end, the editor **402** comprises a plurality of editing tools **410**, for example embodied in a graphical user interface such as a task bar. In further embodiments, the editor **402** is also adapted to receive feedback directly from deployed active ontologies **408**. In one embodiment, the editor **402** is a stand-alone application (e.g., a Java (Swing) stand-alone application).

The console **404** is also interfaced to the server **406** and is adapted to graphically model the application domain as an active ontology (e.g., by enabling the dragging and dropping and linking of objects and tasks) and to construct user queries (e.g., service requests) to be posed to the server **406**, for example using a graphical user interface. Active ontologies constructed using the console **404** are stored at the server **406**. The console **404** is further adapted to receive and display query results (e.g., specific stored active ontologies **408**) sent by the server **406**. In further embodiments, the console **404** is also adapted to stimulate deployed active ontologies **408** by sending new observed facts to the server **406**. In one embodiment, the console **404** is a stand-alone application (e.g., a Java (Swing) stand-alone application).

FIG. 5 is a schematic diagram illustrating one embodiment of a framework **500** for dynamically registering and coordinating distributed services using active ontologies. Specifically, the framework **500** uses active ontologies to register remote services **508₁-508_n** (e.g., information services such as those for hotels, movies, etc., hereinafter collectively referred to as “services **508**”) from a service-oriented architecture **502** (e.g., Web Services). These services **508** may then be implemented by an intelligent automated assistant, “on the fly”, to accomplish one or more tasks. Service-oriented architectures such as Web Services allow the standardized integration of web-based applications using the extensible markup language (XML), simple object access protocol (SOAP), web service definition language (WSDL) and universal description, discovery and integration (UDDI) open standards over an Internet Protocol (IP) backbone.

Thus, the framework **500** includes at least one active ontology **504** interfaced to a service-oriented architecture **502** via a service broker **506**. As described above, the active ontology **504** graphically models a relevant domain (e.g., the objects in the relevant environment and the associated tasks to be accomplished) using a plurality of concepts or active processing elements **510₁-510_n** (used, for example, for service registration, language recognition, activity and/or time recognition, task automation, etc.) that communicate through message passing.

The service broker **506** is adapted to communicate asynchronously with the remote service-oriented architecture **502** and with the active processing elements **510** to select specific services **508** (e.g., based on meta-data about the services **508**, including, for example, the service’s call patterns or quality across various dimensions such as time, cost and completeness), to delegate tasks, queries and updates, and to monitor requests for services.

A service **508** registers with the active ontology **504** by specifying the active processing elements **510** that the service **508** can or cannot accept. Thus, the active ontology **504** is used to filter service requests to the appropriate services **508**.

The framework **500** enables the rapid development of a system having capabilities similar to an open agent architecture framework (e.g., the framework **500** can dynamically, broker, register and coordinate distributed services to resolve user queries and perform requested tasks). More-

over, the framework **500** enables better follow-ups and dialogues with users, flexible definition of timing constraints and task execution and recognition, and can adapt a user interface to the level of a specific user.

FIG. **6** is a high level block diagram of the present intelligent system building method that is implemented using a general purpose computing device **600**. In one embodiment, a general purpose computing device **600** comprises a processor **602**, a memory **604**, an intelligent system building module **605** and various input/output (I/O) devices **606** such as a display, a keyboard, a mouse, a modem, and the like. In one embodiment, at least one I/O device is a storage device (e.g., a disk drive, an optical disk drive, a floppy disk drive). It should be understood that the intelligent system building module **605** can be implemented as a physical device or subsystem that is coupled to a processor through a communication channel.

Alternatively, the intelligent system building module **605** can be represented by one or more software applications (or even a combination of software and hardware, e.g., using Application Specific Integrated Circuits (ASIC)), where the software is loaded from a storage medium (e.g., I/O devices **606**) and operated by the processor **602** in the memory **604** of the general purpose computing device **600**. Thus, in one embodiment, the intelligent system building module **605** for building intelligent systems described herein with reference to the preceding Figures can be stored on a computer readable medium or carrier (e.g., RAM, magnetic or optical drive or diskette, and the like).

Thus, the present invention represents a significant advancement in the field of intelligent systems. The methods and apparatuses of the present invention enable intelligent systems, such as intelligent automated assistants, to be quickly and efficiently developed an “average” programmer (e.g., programmers who are not extensively versed in all necessary fields of technology). Capabilities including natural language interpretation and dialog, multimodal input, adaptable presentation (output), reactive planning, activity recognition/scheduling and coordination of distributed services, among others, can be integrated using a single, visual, unified framework. The manner in which software is built can thus be greatly simplified for many industries, including those which develop or rely on intelligent systems.

While foregoing is directed to the preferred embodiment of the present invention, other and further embodiments of the invention may be devised without departing from the basic scope thereof, and the scope thereof is determined by the claims that follow.

What is claimed is:

1. A computing device, comprising:

one or more processors;
memory; and

one or more programs stored in memory, the one or more programs including instructions for:
collecting at least one input corresponding to one or more events associated with an operating environment of the computing device;

obtaining priorities associated with a plurality of active processing elements included in an active ontology, of an intelligent automated assistant, each active processing element being configured to perform one or more actions responsive to receiving one or more inputs of the collected at least one input;

processing, based on the obtained priorities, the collected at least one input using the plurality of active processing elements;

identifying at least one action based on results of the plurality of active processing elements processing the collected at least one input, wherein identifying the at least one action comprises, identifying based on the processing results, one or more actions associated with valid conditions; and

executing the identified at least one action.

2. The computing device of claim **1**, wherein collecting at least one input comprises:

receiving the at least one input via one or more sensors distributed in the operating environment of the computing device.

3. The computing device of claim **1**, wherein collecting at least one input comprises:

receiving the at least one input via a multimodal user interface.

4. The computing device of claim **1**, wherein the at least one action comprises at least one of: activity recognition, time recognition, natural language processing, reactive activity execution, rule-based planning, automated scheduling, task automation, temporal constraint management, and service brokering.

5. The computing device of claim **1**, wherein the at least one input is tagged with an associated context and a current execution pass.

6. The computing device of claim **1**, wherein processing, based on the obtained priorities, the collected at least one input using the plurality of active processing elements comprises:

processing the collected at least one input in accordance with an order of priority associated with the plurality of active processing elements, wherein the order of priority is from highest priority to the lowest priority.

7. The computing device of claim **6**, wherein processing the collected at least one input in accordance with an order of priority associated with the plurality of active processing elements comprises:

for each active processing element of the plurality of active processing elements, processing the collected at least one input using a plurality of rules of the corresponding active processing element in accordance with an order of priority associated with the plurality of rules.

8. The computing device of claim **7**, wherein each rule of the plurality of rules comprises a condition and an associated action.

9. The computing device of claim **8**, wherein processing the collected at least one input using a plurality of rules comprises:

determining whether the collected at least one input match with a condition associated with each rule of the plurality of rules.

10. The computing device of claim **1**, wherein processing, based on the obtained priorities, the collected at least one input using the plurality of active processing elements comprises:

sharing information among at least two of the plurality of active processing elements.

11. The computing device of claim **10**, wherein sharing information among at least two of the plurality of active processing elements comprises:

propagating information from a first active processing element to a second active processing element, wherein the information propagated is weighted or associated with a probability.

12. The computing device of claim 1, wherein the plurality of active processing elements is associated with a specific context.

13. The computing device of claim 1, wherein the plurality of active processing elements included in the active ontology are arranged in an ontology-like manner such that each active processing element of the plurality of active processing elements is communicatively coupled to at least one other active processing element.

14. The computing device of claim 13, wherein active processing elements that are communicatively coupled share processing results with one another.

15. The computing device of claim 1, wherein processing the collected at least one input using the plurality of active of active processing elements is further based on a predefined order of priority.

16. A method for processing inputs in accordance with an active ontology, comprising:

at a computing device including one or more processors and a memory;

collecting at least one input corresponding to one or more events associated with an operating environment of the computing device;

obtaining priorities associated with a plurality of active processing elements included in the active ontology of an intelligent automated assistant, each active processing element being configured to perform one or more actions responsive to receiving one or more inputs of the collected at least one input;

processing, based on the obtained priorities, the collected at least one input using the plurality of active processing elements;

identifying at least one action based on results of the plurality of active processing elements processing the collected at least one input, wherein identifying the at least one action comprises, identifying based on the processing results, one or more actions associated with valid conditions; and

executing the identified at least one action.

17. The method of claim 16, wherein collecting at least one input comprises:

receiving the at least one input via one or more sensors distributed in the operating environment of the computing device.

18. The method of claim 16, wherein collecting at least one input comprises:

receiving the at least one input via a multimodal user interface.

19. The method of claim 16, wherein the at least one action comprises at least one of:

activity recognition, time recognition, natural language processing, reactive activity execution, rule-based planning, automated scheduling, task automation, temporal constraint management, and service brokering.

20. The method of claim 16, wherein the at least one input is tagged with an associated context and a current execution pass.

21. The method of claim 16, wherein processing, based on the obtained priorities, the collected at least one input using the plurality of active processing elements comprises:

processing the collected at least one input in accordance with an order of priority associated with the plurality of active processing elements, wherein the order of priority is from highest priority to the lowest priority.

22. The method of claim 21, wherein processing the collected at least one input in accordance with an order of priority associated with the plurality of active processing elements comprises:

for each active processing element of the plurality of active processing elements, processing the collected at least one input using a plurality of rules of the corresponding active processing element in accordance with an order of priority associated with the plurality of rules.

23. The method of claim 22, wherein each rule of the plurality of rules comprises a condition and an associated action.

24. The method of claim 23, wherein processing the collected at least one input using a plurality of rules comprises:

determining whether the collected at least one input match with a condition associated with each rule of the plurality of rules.

25. The method of claim 16, wherein processing, based on the obtained priorities, the collected at least one input using the plurality of active processing elements comprises:

sharing information among at least two of the plurality of active processing elements.

26. The method of claim 25, wherein sharing information among at least two of the plurality of active processing elements comprises:

propagating information from a first active processing element to a second active processing element, wherein the information propagated is weighted or associated with a probability.

27. The method of claim 16, wherein the plurality of active processing elements is associated with a specific context.

28. The method of claim 16, wherein the plurality of active processing elements included in the active ontology are arranged in an ontology-like manner such that each active processing element of the plurality of active processing elements is communicatively coupled to at least one other active processing element.

29. The method of claim 28, wherein active processing elements that are communicatively coupled share processing results with one another.

30. The method of claim 16, wherein processing the collected at least one input using the plurality of active of active processing elements is further based on a predefined order of priority.

31. A non-transitory computer-readable storage medium storing one or more programs, the one or more programs comprising instructions, which when executed by one or more processors of a computing device, cause the computing device to:

collect at least one input corresponding to one or more events associated with an operating environment of the computing device;

obtain priorities associated with a plurality of active processing elements included in the active ontology of an intelligent automated assistant, each active processing element being configured to perform one or more actions responsive to receiving one or more inputs of the collected at least one input;

process, based on the obtained priorities, the collected at least one input using the plurality of active processing elements;

identify at least one action based on results of the plurality of active processing elements processing the collected at least one input, wherein identifying the at least one

11

action comprises, identifying based on the processing results, one or more actions associated with valid conditions; and
 execute the identified at least one action.

32. The non-transitory computer-readable storage medium of claim 31, wherein collecting at least one input comprises:
 receiving the at least one input via one or more sensors distributed in the operating environment of the computing device.

33. The non-transitory computer-readable storage medium of claim 31, wherein collecting at least one input comprises:
 receiving the at least one input via a multimodal user interface.

34. The non-transitory computer-readable storage medium of claim 31, wherein the at least one action comprises at least one of: activity recognition, time recognition, natural language processing, reactive activity execution, rule-based planning, automated scheduling, task automation, temporal constraint management, and service brokering.

35. The non-transitory computer-readable storage medium of claim 31, wherein the at least one input is tagged with an associated context and a current execution pass.

36. The non-transitory computer-readable storage medium of claim 31, wherein processing, based on the obtained priorities, the collected at least one input using the plurality of active processing elements comprises:
 processing the collected at least one input in accordance with an order of priority associated with the plurality of active processing elements, wherein the order of priority is from highest priority to the lowest priority.

37. The non-transitory computer-readable storage medium of claim 36, wherein processing the collected at least one input in accordance with an order of priority associated with the plurality of active processing elements comprises:
 for each active processing element of the plurality of active processing elements, processing the collected at least one input using a plurality of rules of the corresponding active processing element in accordance with an order of priority associated with the plurality of rules.

12

38. The non-transitory computer-readable storage medium of claim 37, wherein each rule of the plurality of rules comprises a condition and an associated action.

39. The non-transitory computer-readable storage medium of claim 38, wherein processing the collected at least one input using a plurality of rules comprises:
 determining whether the collected at least one input match with a condition associated with each rule of the plurality of rules.

40. The non-transitory computer-readable storage medium of claim 31, wherein processing, based on the obtained priorities, the collected at least one input using the plurality of active processing elements comprises:
 sharing information among at least two of the plurality of active processing elements.

41. The non-transitory computer-readable storage medium of claim 40, wherein sharing information among at least two of the plurality of active processing elements comprises:
 propagating information from a first active processing element to a second active processing element, wherein the information propagated is weighted or associated with a probability.

42. The non-transitory computer-readable storage medium of claim 31, wherein the plurality of active processing elements is associated with a specific context.

43. The non-transitory computer-readable storage medium of claim 31, wherein the plurality of active processing elements included in the active ontology are arranged in an ontology-like manner such that each active processing element of the plurality of active processing elements is communicatively coupled to at least one other active processing element.

44. The non-transitory computer-readable storage medium of claim 43, wherein active processing elements that are communicatively coupled share processing results with one another.

45. The non-transitory computer-readable storage medium of claim 31, wherein processing the collected at least one input using the plurality of active of active processing elements is further based on a predefined order of priority.

* * * * *